

# Series 275 AFCO - Level Cable Rail









## INSTALLATION INSTRUCTIONS

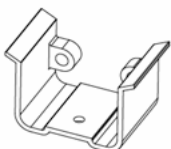
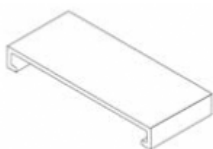
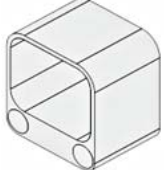

**AFCO**  
Columns and Railings  
a Division of AFCO Industries, Inc.

### PARTS INCLUDED:

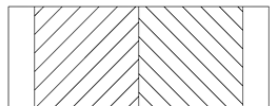
<b>TOP RAIL—TOP RAIL (1)</b>		<b>BOTTOM RAIL— BOTTOM RAIL (1)</b>	
<b>A</b> 		<b>B</b> 	
<b>SADDLE BRACKET (2)</b>	<b>BRACKET COVER (2)</b>	<b>BOTTOM BRACKET (2)</b>	<b>10" SUPPORT BLOCK (1)</b>
<b>C</b> 	<b>D</b> 	<b>E</b> 	<b>F</b> 
<b>SUPPORT BLOCK CONNECTOR (2)</b>	<b>#10x1" SELF DRILLING SCREW (12)</b>	<b>3 1/2 " DRIVER BIT (1)</b>	<b>ADHESIVE TAB SHEET (1)</b>
<b>G</b> 	<b>H</b> 	<b>I</b> 	<b>J</b> 

### TOOLS REQUIRED:

- Drill bit 5/32" (.156")
- Drill Bit 9/32" (.281)
- Drill bit 29/64" (.453)
- 1/8" hex wrench
- 7/16" wrench
- Drill (with adjustable clutch, recommended)
- Miter Saw (with metal cutting blade)
- Level
- Rubber mallet
- Tape measure
- Cable cutters
- Grinder with cutoff wheel
- Touch-up paint

### PRE-DRILLED CABLE BALUSTER

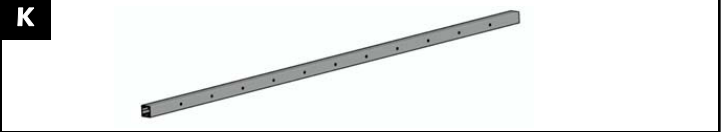

### NOTES:

- *NOTE: Cables for this rail system are sold separately.*
- Posts packaged separately.
- An Optional AFCO-Tool is available to simplify the locating, pre-drilling and installation of brackets.

### FOR A SUCCESSFUL INSTALLATION:

- Read the instructions completely before beginning the installation.
- Plan your railing project. Sketch your project with the actual measurements of your deck or balcony complete with post locations.
- Check local building codes to ensure compliance.
- Check carton(s) to determine part count is complete.
- After cutting rails, balusters, or posts, paint exposed metal for maximum protection against the elements.
- Installation is best accomplished with two people.
- Wear personal protection equipment; safety glasses, etc.
- Use care not to over-torque the screws. Pre-drilling is recommended.
- **Provided hardware to install AFCO-Rail is for use with Aluminum AFCO-Rail posts. If installing to other surfaces the installer must acquire the appropriate hardware as needed for proper installation.**

**POSTS INSTALLATION:**

1. Measure and locate the position of the post(s) based on the project layout. Pre drilled holes must be installed in-line with the direction the cables will follow.

2. Install the post by attaching the aluminum mounting flange to the surface of the deck or balcony. Position the post so the fastener will go into the floor joist, and make sure the decking is firmly attached to the joist at the location of the post. If necessary, use wood blocking as reinforcement underneath the decking where the posts are located. Post mounting fasteners should be able to secure into the joist or reinforcement braces, not just the decking itself. When installing AFCO-Rail Post on top of a wood surface, screws must be lagged into at least 3" of solid wood. Deck boards sized 5/4" or 1-1/2" do not provide sufficient material for a safe installation.

*Note: When installing AFCO-Rail Post onto treated wood surface, install the provided ACQ pad (included in the post kit) between the post base and the treated surface.*

3. Position the post to the deck surface. Four 3/8" diameter mounting holes are provided on the mounting flange. Mark the mounting flange hole locations and remove the post. Pre-drill the marked locations into the decking and reinforcement for the appropriate fasteners. Remount the post with the pre-drilled holes for the cables in the correct direction per the project requirements. Insert the appropriate fasteners to secure the mounting flange to the deck structure.

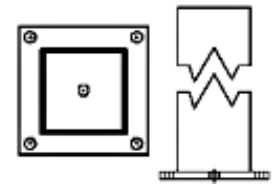

4. Finish by sliding the base trim to the bottom of the post to cover the mounting flange.

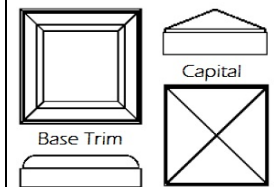

5. To install the post cap, set post capital in place on top of the post and tap lightly with a rubber mallet to drive the post cap onto the post. Silicone or water based caulking may be used to secure the post cap and base trim. *(Note: Cap installation step is typically completed after all rails have been installed.)*

**LEVEL CABLE RAIL INSTALLATION:**

1. Measure the opening between the installed posts. If required to cut rail shorter than provided, start with the Bottom Rail (B), and mark the rail to the same distance measured between posts. Carefully cut the rail to the required length. Trimming the rail from both ends will be required to keep the support baluster centered between posts. Align the baluster connectors on the top and bottom rail. Mark and cut top rail 3/8" shorter on each end than the bottom rail.



**(The top rail is cut a total of 3/4" shorter than the bottom rail for bracket clearance)**

Note: One Support Block, cut from Support Block Material (F), is recommended for rails measuring 72" or less. Install the Support Block Connector (G) at center point of Bottom Rail (B) If two or more Support Blocks are used, install Support Block Connectors (G) equally distributed from each end of the Bottom Rail (B).

2. Cut 10" Support Block (F) to required length and press over the Support Connector installed on one side of the bottom rail (B). Support block is typically cut at 2", but can be cut to length as needed based on project or code requirements. *(Note: all cut dimensions in this instruction is based on 2" space under the Bottom Rail and 36" height top rail, when using a 3/4" deck board installed on the Top Rail "A". Any variation from this will require additional measuring and planning for bracket placement.)*

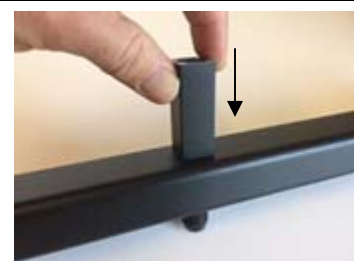

3. The 275 Series Level Deck Rail is to be installed with a deck board on top of the Top Rail (A). To install rail, measure up 34-1/2" (36" rail height) or 40-1/2" (42" rail height) from the floor and mark a level, horizontal line on the post. Align the screw holes in the Saddle Bracket (C) with the horizontal line marked on the post making sure the bracket is centered on the post, and attach Saddle Brackets with #10 x 1" self-drilling screws (H). **Note: If installing without a deck board on the Top Rail (A) overall rail height may not meet code requirements. Raising the top rail to reach height requirements without installing a deck board will cause the cables to not be level due to pre-drilled posts and balusters.**



4. Locate pre-drilled cable baluster (K) and insert over the installed baluster connector on the Bottom Rail (B) with holes facing in line with the rail. Install the Top Rail (A) on the baluster also making sure it is fully seated in place. *A rubber mallet may be required to lightly tap the rail to fully seat on the baluster.*

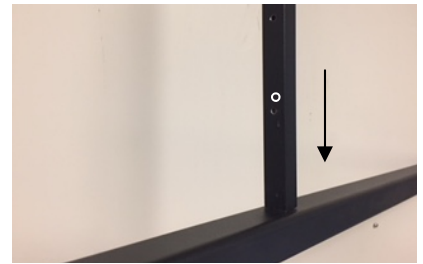

5. If installing without a deck board on the top rail slide the Bracket Covers (D) on each end of the top rail (A) approximately 3 - 4 inward. *Note: A small piece of tape may be required to temporarily hold covers on top rail.*

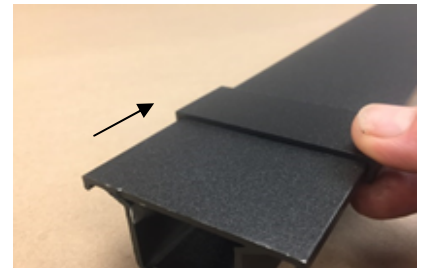

6. Slide the Bottom Brackets (E) on each end of the Bottom Rail (B) with holes facing down and counter bore holes facing towards baluster.



7. Set the assembled rail in place with Top Rail (A) placed in the Saddle Brackets (C) and let the Bottom Rail (B) hang freely between the posts. *Added temporary spacers the same thickness as the support block installed in step 3 placed under each end of the bottom rail will help to level the rail to install the bottom brackets.*

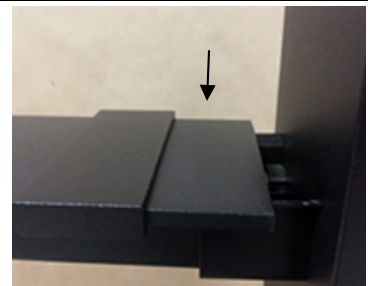

8. Slide and hold the Bottom Brackets (E) centered, and firmly against the post. Secure each bracket with self drilling screws (H). *Note: Screw holes are angled to make mounting brackets easier to install. An AFCO Tool will help with centering and locating the brackets in this step. (Pre-drilling is recommended.)*



9. Apply adhesive tab (J) to flat surface of Top Rail (A) near the post. Slide Bracket Cover (D) to interlock with the flange on the saddle bracket.



10. Screw self-drilling screws (H) into the Top Rail (A) from the underside of each Saddle Bracket ( C ) through the provided locating hole to securely fasten the rail.

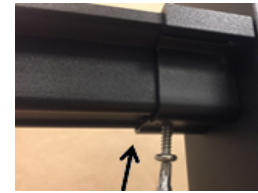

**CABLE INSTALLATION**

1. Drill out and enlarge the holes in the outermost wall *only* of the first post with a 9/32" drill bit through the holes already in the post, and also drill the outermost wall *only* on the opposite end of the cable run with a 29/64" drill bit. This step is to allow the cable fittings to be installed.



2. Remove cable and fittings from packages and install the required small stainless washer and brass nut on the threaded stud end of the cables, and feed the bare ends of the cable through all posts and support balusters starting at the holes drilled out to 9/32".



3. Slide Line Fittings with required round black washers onto the cables while twisting in a clockwise motion until the fittings are fully seated in the end post. Pull the bare ends to remove as much slack as possible. Trim all ends of the cable sticking out of the fittings with a cutoff wheel and press the cap onto the fittings.



4. Return to the treaded stud end of the cables and starting with the centermost cable insert a 1/8" hex wrench into the end of the treaded stud. Tighten the locknut with a 7/16" wrench while holding the hex wrench to prevent the cable from turning.



5. It is recommended that you follow the sequence of tensioning the cables starting at the center and alternating above and below until all cables are properly tensioned. As cables are tensioned give a sharp pull downward mid-span to set the fitting wedges, then re-tension as necessary in the same sequence.

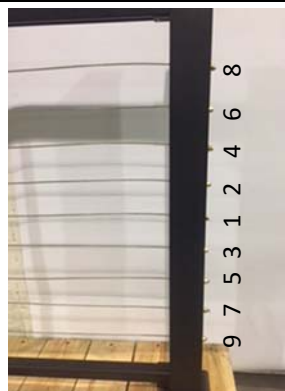

6. When all cables are tight, cut off any exposed threads near the locknut as possible using a cut-off wheel or hacksaw. Press the nut cap over the locknut.

