



## Code Compliance Research Report

## CCRR-0163

Subject to Renewal: 10/13/2016  
Visit [www.ati-es.com](http://www.ati-es.com) for current status

Issued: 12/17/2014  
Revised: 10/30/2015  
Page 1 of 16

**Digger Specialties, Inc.**  
3446 US 6 East  
Bremen, Indiana 46506  
(574) 546-5999  
[www.diggerspecialties.com](http://www.diggerspecialties.com)

### 1.0 Subject

#### Westbury® Aluminum Railing

- Tuscany Series* (Style C10)
- Riviera Series* (Styles C30, C30R, C31, C32, C33, and C34)
- Veranda Series* (Style C70)
- VertiCable Series* (Style C80)

### 2.0 Research Scope

#### 2.1. Building Codes:

- 2012 International Building Code (IBC)
- 2012 International Residential Code (IRC)
- 2009 International Building Code (IBC)
- 2009 International Residential Code (IRC)
- 2010 Florida Building Code (FBC):
  - including High Velocity Hurricane Zone (HVHZ) for *Tuscany* and *Riviera Series*;
  - excluding High Velocity Hurricane Zone (HVHZ) for *Veranda Series*

#### 2.2. Properties:

Structural Performance

### 3.0 Description

3.1. General – The *Westbury®* Aluminum Railing system is a guardrail under the definitions of the referenced codes. It is intended for use at or near the open sides of elevated walking areas of buildings and walkways as required by the codes.

3.2. Guardrail Assemblies – Guardrails are provided as level guardrails for level walking areas such as decks, balconies, and porches. Level guardrails are provided with rail lengths up to 96 inches in length (measured between the inside of support posts) and an installed height

of 36 inches or 42 inches. See Table 1 for qualified configurations.

3.3. Materials and Processes – The *Westbury®* Aluminum Railing system is an assemblage of extruded aluminum materials, extruded PVC rail inserts, tempered glass panels, austenitic (300 series) stainless steel fasteners, and cast Zamak 3 bracket materials.

3.3.1. The system is available in various colors and architectural grade powder coated finishes.

3.4. Components - The guardrail system includes a top rail, a mid-rail (*Riviera Series*), a bottom rail, vertical balusters, a structural aluminum post, rail-to-post brackets, a support block, and decorative moldings and post caps.

3.4.1. Rails - Each of the top, mid, and bottom aluminum rails are routed to accept various infill components described in Section 3.4.2 for the various railing systems as shown in Figure 1 through 10.

3.4.1.1. The *Tuscany, Riviera and Veranda* top rails are extruded 6005-T5 aluminum rails with internal longitudinal ribs, and dimensions of 1.74 inches wide by 1.38 inches tall. The *Tuscany* and *Riviera Series* use a PVC rail insert as a baluster retainer. The *Veranda Series* uses a rubber insert as a glass infill retainer. See Figure 15.

3.4.1.2. The *VertiCable* top rail is an extruded 6005-T5 aluminum rail with internal longitudinal ribs, dimensions of 1.74 inches wide by 1.38 inches tall and a 0.14 inch x 1-3/16 inch wide 6005-T5 aluminum plate that is drilled for the cable and baluster infills. See Table 2 for the cable fastening schedule and Figure 23 for cross sections of the *VertiCable* top rail sections.

3.4.1.3. The mid-rail is an extruded 6005-T5 aluminum rail with internal longitudinal ribs, dimensions of 1.74 inches wide by 1.25 inches tall. A PVC rail insert is used as a baluster retainer. See Figure 13.

3.4.1.4. The *Tuscany, Riviera and Veranda* bottom rails are extruded 6005-T5 aluminum rails with internal longitudinal ribs and are 1.74 inches wide by 1.25 inches tall. A PVC rail

insert is used as a baluster retainer. See Figure 12.

3.4.1.5. The *VertiCable* bottom rail is an extruded 6005-T5 aluminum rail with internal longitudinal ribs and is 1.74 inches wide by 1.25 inches tall. A 11/16 inch high x 1-1/2 wide x 0.09 inch thick U-profile, made from 6005-T5 aluminum is inserted into the bottom rail. This insert is drilled for the retaining of the cable and round baluster infills. See Table 2 for the cable fastening of the infills. See Figure 25 for a cross section of the *VertiCable* bottom rail.

3.4.2. The guardrail infills vary by guardrail style.

3.4.2.1. The *Tuscany Series* (Style C10), utilizes 6063-T6 aluminum balusters in various lengths (See Figure 16).

3.4.2.2. The *Veranda Series* (Style C70) infill area of the railing system (see Figure 8) utilizes a 1/4 inch thick tempered glass panel in various sizes.

3.4.2.3. The *Riviera Series* Style C30R infill area of the railing system (see Figure 3) is configured with 6063-T6 aluminum balusters and with tabbed 6063-T6 aluminum rings between the top and mid-rail. See Figure 16.

3.4.2.4. The *VertiCable* (Style C80) infill area utilizes 1/8" diameter, 1x19, S31600 stainless steel cables spaced at 3.75 inches (See Figure 9). Also, see Table 2 for cable fastening methods.

3.5. Structural Aluminum Posts:

3.5.1. *Power Posts* are a 2-1/2 inch square by 0.125 inch wall extruded 6005-T5 aluminum tube with internal screw slots. The tube is connected to a 4-1/2 inch square, 1/2 inch thick 6061-T6 aluminum base plate via both a 1/4 inch continuous fillet weld and six #14 by 2 inch flat-head screws. For the standard *Power Post*, see Table 2 and Figure 20. For the *Power Post* crossover assembly, see Table 2 and Figure 20.

3.5.2. The 4x4 aluminum post is a 4 inch square by 0.125 inch wall extruded 6063-T6 aluminum tube. The tube is permanently attached to a 6 inch square, 1/2 inch thick 6061-T6 aluminum base plate by a 1/4 inch continuous fillet weld. See Table 2 and Figure 22.

3.5.3. 2 inch Alum Support Posts are a 2 inch square by 0.09 inch wall extruded 6005-T5 aluminum tube with internal screw slots. The tube is connected to a 3-7/8 inch square, 1/2 inch thick 6061-T6 aluminum base plate via both a 1/4 inch continuous fillet weld and two #14-14 by 2 inch flat-head screws. For the Alum Support Post, see Table 2 and Figure 23.

3.5.4. A support block is installed between the lower rail and the deck surface midway between supports, with the exception of Westbury C-10 Tuscany railings that are 72 inches or less between posts. See Figure 18.

#### 4.0 Performance Characteristics

4.1. The guardrail system described in this report has demonstrated the capacity to resist the design loadings specified in Chapter 16 of both the IBC and the FBC and Section R301 of the IRC when tested in accordance with ICC-ES AC273.

#### 5.0 Installation

The guardrail system shall be installed in accordance with the Digger Specialties, Inc.'s installation instructions and this report. Where differences occur between this report and Digger Specialties, Inc.'s installation instructions, this report shall govern.

5.1. The top and bottom rails are attached directly to structural posts utilizing cast Zamak 3 mounting brackets via mechanical fasteners. See Figure 19 and Table 2.

5.2. Guardrails may be assembled in various configurations. Refer to Figure 1 through Figure 10 for overall assembly and Table 2 for the fastening schedule.

5.3. Infill components (aluminum balusters and aluminum rings) are inserted into routed holes in the aluminum rails and secured via PVC rail inserts that are installed internally to the rails. See Figure 14.

5.4. The infill component for the *Veranda Series* (Style C70) consists of a glass panel which is inserted into the top rail and slides up, to clear bottom rail. The glass panel is aligned with the bottom insert and pushed down into that insert.

5.5. The cable infill for the VertiCable consists of both 1/8 inch diameter stainless steel cables and 9/16 inch diameter aluminum balusters. The steel cables must be installed with the Zamak 3 cable tensioner below the bottom rail tensioned to 40 in-lbs of torque.

5.6. Two shim plates are utilized under the base of the structural post. Each shim plate is oriented so that its length is parallel with the line of the rail. The hardware used to anchor the base of the 2" *Alum Support Post, the 2-1/2" Power Post* and 4x4 aluminum post to the supporting structure is installed so that it passes through the holes in the shim plates.

5.7. *Power Post* shim plates are 4-1/2 inches long by 3/4 inch wide by 1/16 inch thick austenitic (300 series) stainless steel plates. The 4x4 aluminum post shim plates are 6 inches long by 3/4 inch wide by 0.06 inch thick austenitic (300 series) stainless steel plates.

## 6.0 Supporting Evidence

6.1. Drawings and installation instructions submitted by Digger Specialties, Inc.

6.2. Reports of testing demonstrating compliance with the performance requirements of ICC-ES AC273, Acceptance Criteria for Handrails and Guards, effective March 1, 2008 with additional testing including increased test loads to address IBC and FBC Section 2407.1.1 for assemblies that utilize a glass in-fill panel.

6.3. A quality control manual that is in accordance with the ICC-ES AC10, Acceptance Criteria for Quality Documentation, approved June 2011.

## 7.0 Conditions of Use

The guardrail assemblies identified in this report are deemed to comply with the intent of the provisions of the referenced building codes subject to the following conditions.

7.1. Attachment of guardrail systems described herein to conventional wood supports is outside the scope of this report.

7.2. Shim plates must be used for all structural post installations as described in Section 5.6.

7.3. Anchorage of the structural post is not within the scope of this report and is subject to evaluation and approval by the building official. Anchors must satisfy the design load requirements specified in Chapter 16 of the

building code and must meet the following minimum requirements:

7.3.1. A minimum of four anchor bolts must be used and located in the four pre-drilled holes in the structural post base plate.

7.3.2. The anchors must have a minimum nominal diameter equal to 3/8 inch.

7.3.3. When the supporting structure is a wood-framed deck, installation must include anchorage to suitable structural framing. Decking is not considered structural framing, and anchorage to decking alone is not an approved installation method.

7.3.4. Where required by the building official, engineering calculations and details shall be provided. The calculations shall verify that the anchorage and supporting structure complies with the building code for the type and condition of the supporting construction.

7.4. The glass infill panel of guardrails is considered a hazardous location as defined by Sections 2406.4 of the IBC and 2406.3 of the FBC. Glass must be identified by permanent etching as required by Sections 2406.3 of the IBC and 2406.2 of the FBC. Each section of glass must bear the manufacturer's name or mark and the applicable test standard. (Class A of ANSI Z97.1 and Category II of 16 CFR 1201).

7.5. Guardrails utilizing glass infill are not approved for use in wind-borne debris regions as defined by the IBC in accordance with Section 2407.1.4. Thus, glass balusters are also not approved for use in the High Velocity Hurricane Zone (HVHZ) under the FBC.

7.6. Digger Specialties, Inc. manufactures the *Westbury*<sup>®</sup> Aluminum Railing system in Bremen, Indiana in accordance with an approved quality control system that includes independent third party inspections by NTA, Inc. (IAS AA-682).

## 8.0 Identification

The *Westbury*<sup>®</sup> Aluminum Railing guardrail assemblies that are described in this report shall be identified with labeling on the individual components and/or the packaging such that the product is identifiable at the point of use. The label shall include at least the following information:

8.1. Name and/or trademark of Digger Specialties, Inc.

8.2. The name and/or identifying mark of the independent inspection agency (NTA Inc.).

8.3. For 36" high guardrail systems, the label shall also include the phrase, "For Use in One- and Two-Family Dwellings Only."

8.4. The Architectural Testing Code Compliance Research Report mark and number (CCRR-0163).

### 9.0 Code Compliance Research Report Use

9.1. Approval of building products and/or materials can only be granted by a building

official having legal authority in the specific jurisdiction where approval is sought.

9.2. Code Compliance Research Reports shall not be used in any manner that implies an endorsement of the product by Architectural Testing.

9.3. Reference to the Architectural Testing internet web site address at [www.ati-es.com](http://www.ati-es.com) is recommended to ascertain the current version and status of this report.

**Table 1 – Guardrail Systems and Use Categories**

<b><u>Westbury® Aluminum Railing System</u></b>	<b><u>Guardrail Type</u></b>	<b><u>Code Occupancy Classification</u></b> <sup>1</sup>			
		<b><u>IBC</u></b> <sup>5</sup>	<b><u>IRC</u></b> <sup>6</sup>	<b><u>FBC</u></b> <sup>5</sup>	<b><u>FBC-Residential</u></b> <sup>6</sup>
<i>Tuscany Series &amp; Riviera Series</i>	Level	8' x 42"	8' x 36" <sup>2</sup> 8' x 42"	8' x 42"	8' x 36" <sup>2,4</sup> 8' x 42"
<i>Tuscany (no center support under bottom rail)</i>	Level	6' x 42"	6' x 36" <sup>2</sup> 6' x 42"	6' x 42"	6' x 36" <sup>2</sup> 6' x 42"
<i>VertiCable Series</i>	Level	6' x 42"	8' x 36" <sup>2</sup> 6' x 42"	6' x 42"	8' x 36" <sup>2</sup> 6' x 42"
<i>Veranda Series</i>	Level	6' x 42" <sup>3</sup>	6' x 36" <sup>2,3</sup> 6' x 42" <sup>3</sup>	6' x 42" <sup>3,4</sup>	6' x 36" <sup>2,3,4</sup> 6' x 42" <sup>3,4</sup>

<sup>1</sup> Guardrails are qualified up to and including the listed maximum guardrail system dimensions for use in the referenced Code Occupancy Classification.

<sup>2</sup> The use of this product shall be limited to exterior use as a guardrail system for balconies and porches for one- and two-family dwellings of Type V-B (IBC, FBC) construction in accordance with the IRC or FBC-Residential.

<sup>3</sup> Excluding wind-borne-debris regions

<sup>4</sup> Excluding High-Velocity-Hurricane-Zone (HVHZ)

<sup>5</sup> Can use either the 2-1/2" *Power Post* or the 4" *Square Aluminum Post*

<sup>6</sup> Can use either the 2" *Square Aluminum Post*, 2-1/2" *Power Post*, or the 4" *Square Aluminum Post*

**Table 2 – Fastener Schedule**

<u>Connection</u>	<u>Fastener</u>
All Rail Brackets to Post	Two #10-16 x 5/8 in pan-head, self-drilling, 18-8, 300 Series screws <sup>2</sup>
Crossover Assembly to Top Rail	
Top Rail and Mid-Rail Bracket to Rail	Two #10-15 x 1 in flat-head, self-drilling, 18-8, 300 Series screws <sup>2</sup> (one through each side hole)
C80 Only - Bottom Rail Bracket to Rail	
Bottom Rail Bracket to Rail	No mechanical fastener
Westbury Riviera Baluster to Rails	Inserted into 0.8 inch square routed hole and held snug with PVC Rail Insert
Westbury Tuscan Baluster to Rails	Inserted into 0.8 inch square routed hole and held snug with PVC Rail Insert
Westbury Veranda Glass Panel to Rails	EPDM gasket retaining glass panel in slotted top and bottom rails
Westbury VertiCable Aluminum Baluster to Rails	Inserted into 9/16 round routed hole
Cable Infill to Top Rail Insert	One 0.23 in diameter (OD) hollow 18-8 stainless steel cable stop sleeve, crimp fit to each cable
Cable Infill to Bottom Rail Insert	One 0.23 in diameter (OD) hollow 18-8 stainless steel cable stop sleeve, crimp fit to each cable and one 3/8 in wide by 7/8 in long threaded (20 TPI) Zamak 3 cable tensioner with 1/2 in 18-8 stainless steel nut per cable
Support Block Screw to Bottom Rail	One #8-18 x 3/4 in pan-head, self-drilling, zinc-plated 18-8, 300 Series screw <sup>2</sup>
Power Post Base Plate to 2-1/2" Structural Post Tube	Six #14-14 x 2 in flat-head, self-drilling, 18-8, 300 Series screws <sup>1,2</sup>
Base Plate to 2" Alum Support Post	Two #14-14 x 2 in trim head, Phillips-drive, 18-8, 300 Series screws <sup>1,2</sup>

<sup>1</sup> Power Posts and 2" Alum Support Posts are supplied with fasteners pre-installed.

<sup>2</sup> Permissible grades of the 300 Series stainless steel material include: 304, 305, 316, 384, and/or XM7 (30430), which are all Austenitic Stainless Steel – Cold Worked materials.

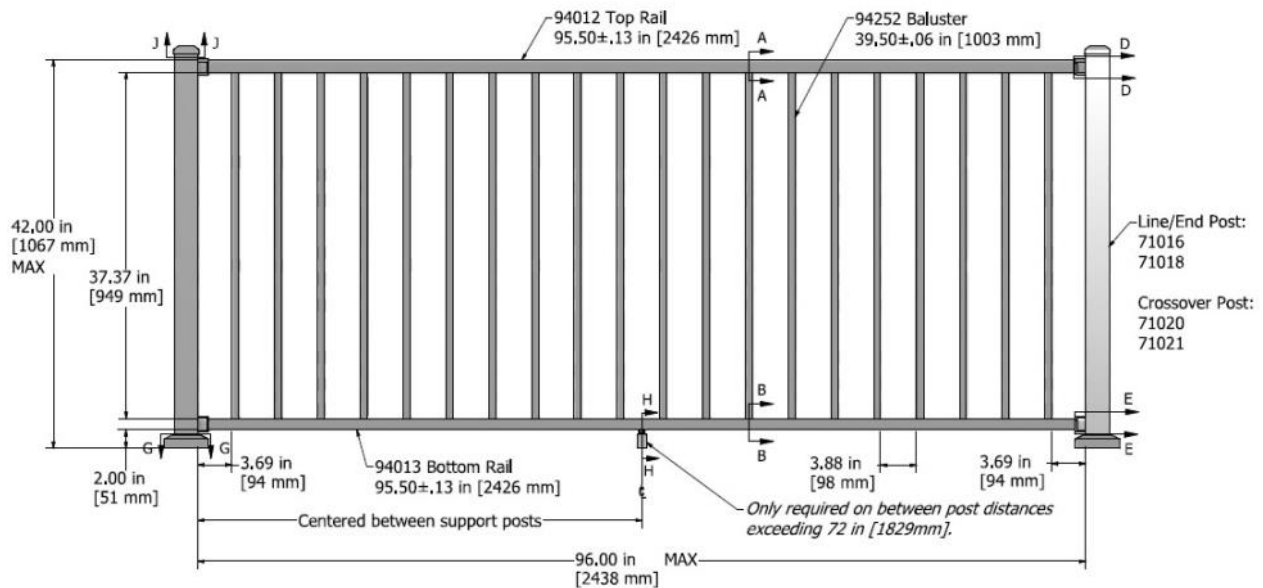

**Figure 1**  
**Westbury® Tuscany Series Style C10 Aluminum Railing System**

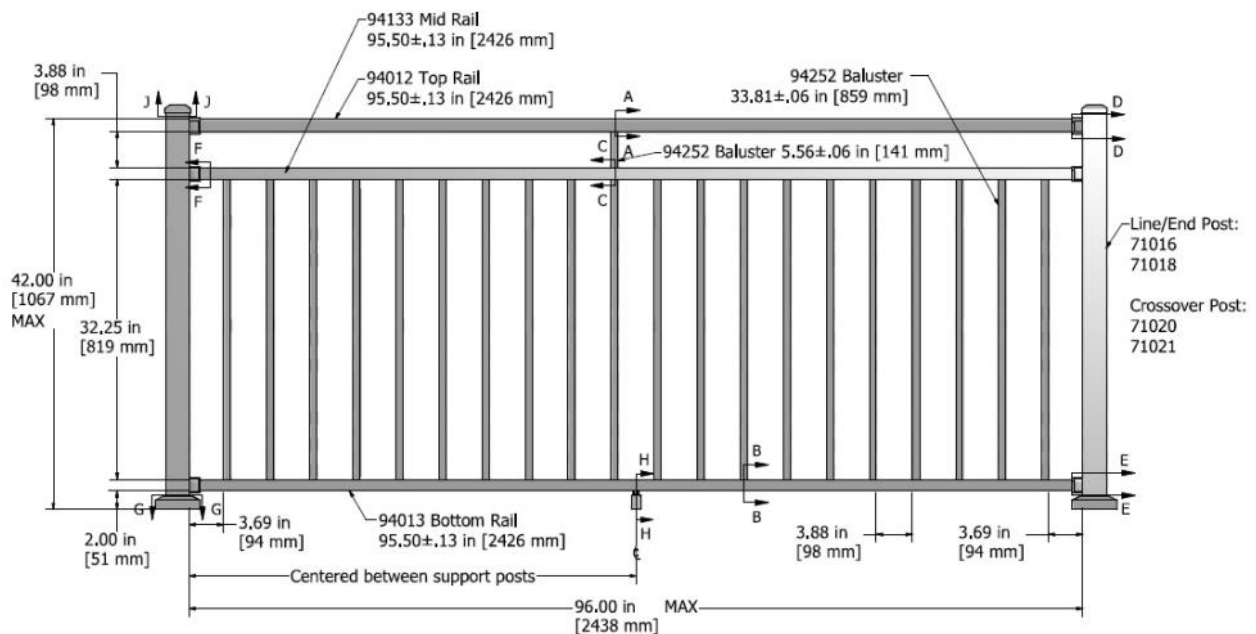

**Figure 2**  
**Westbury® Riviera Series Style C30 Aluminum Railing System**

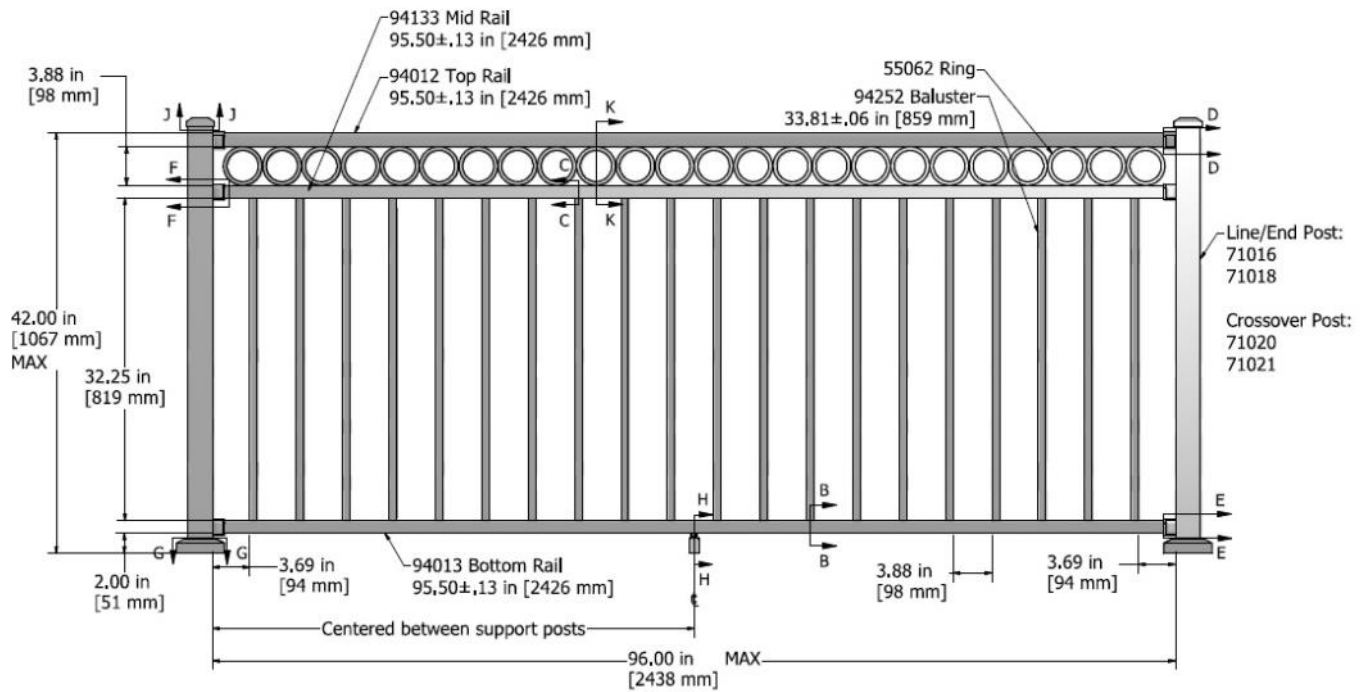

Figure 3  
Westbury® Riviera Series Style C30R Aluminum Railing System

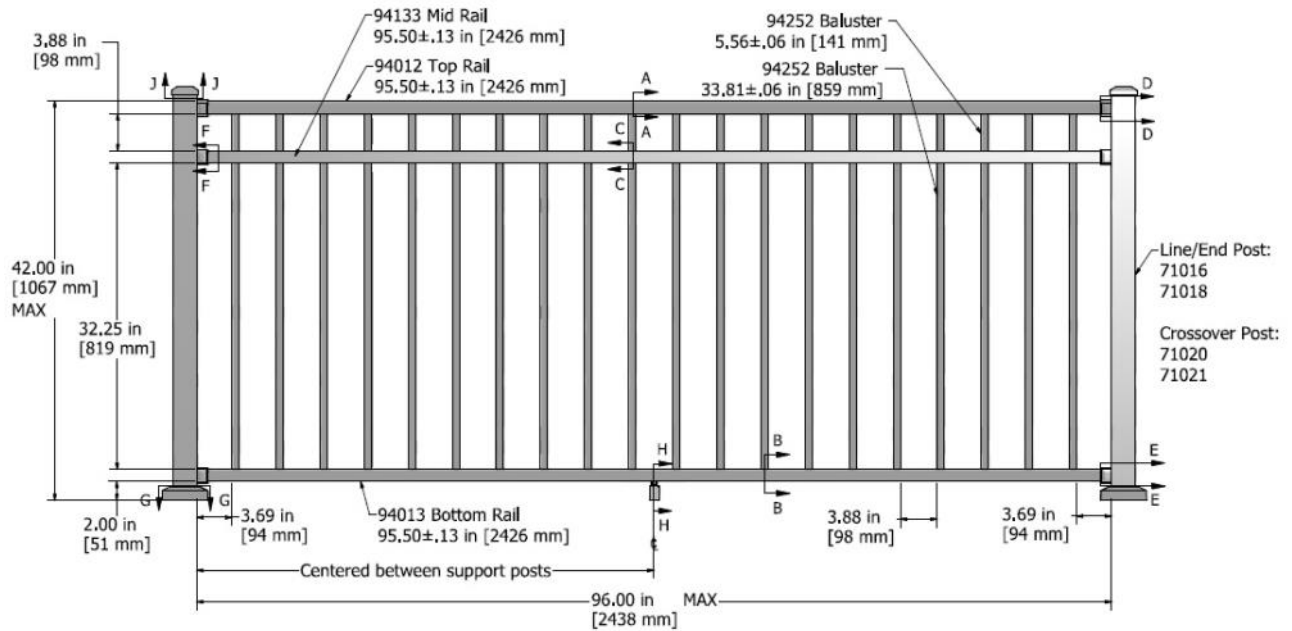

Figure 4  
Westbury® Riviera Series Style C31 Aluminum Railing System

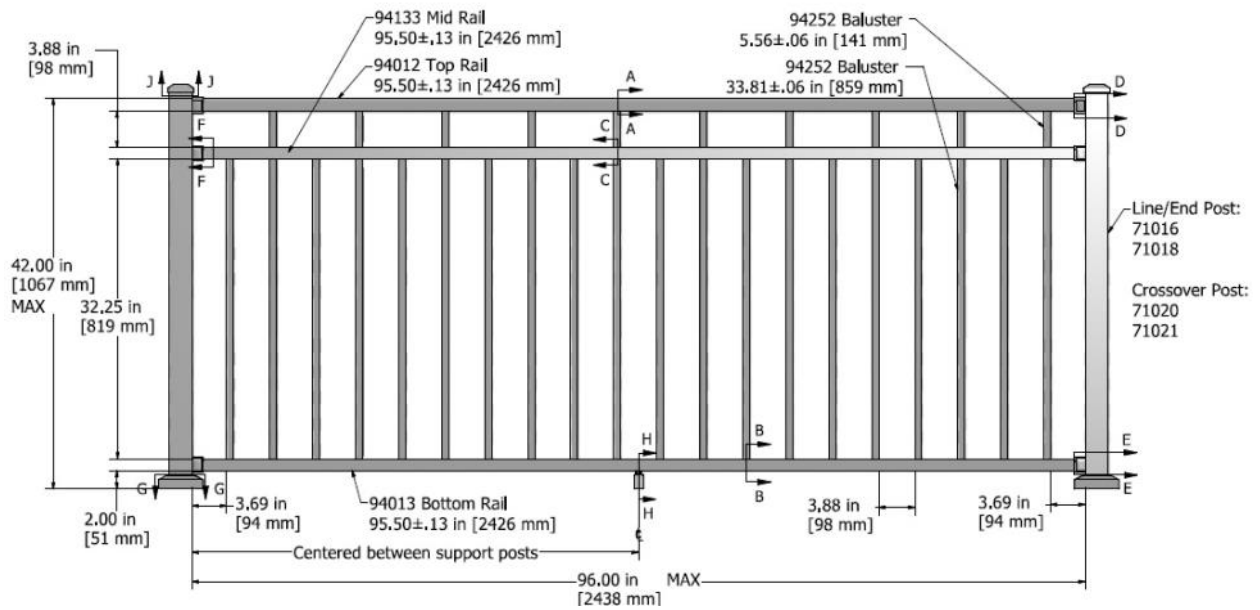

Figure 5  
Westbury® Riviera Series Style C32 Aluminum Railing System

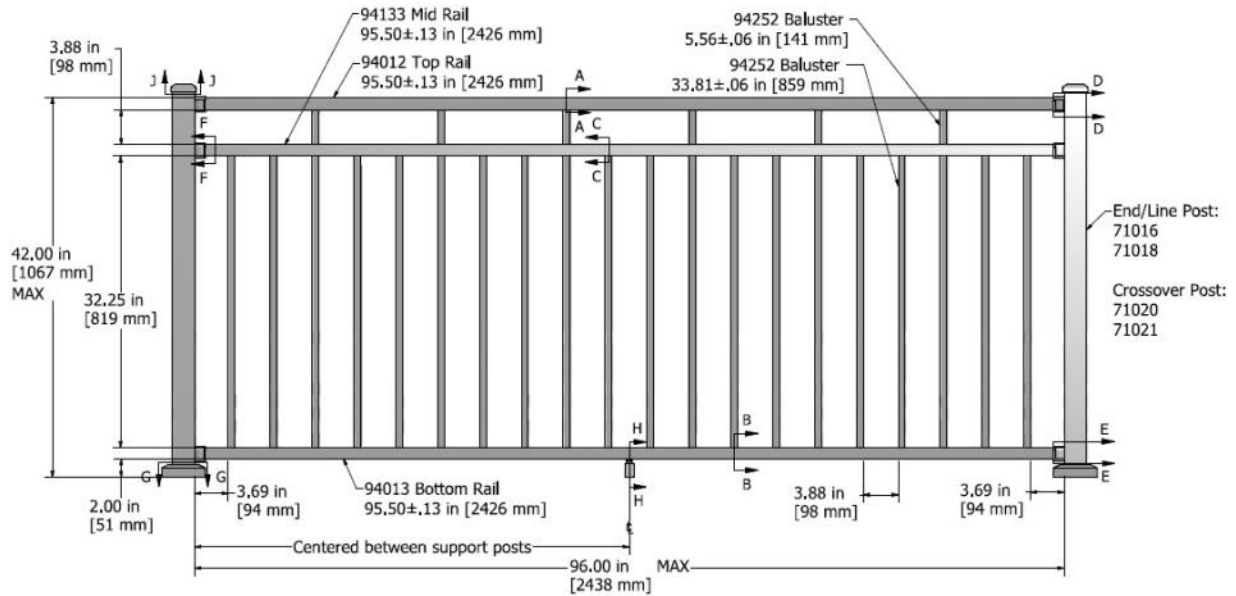

Figure 6  
Westbury® Riviera Series Style C33 Aluminum Railing System



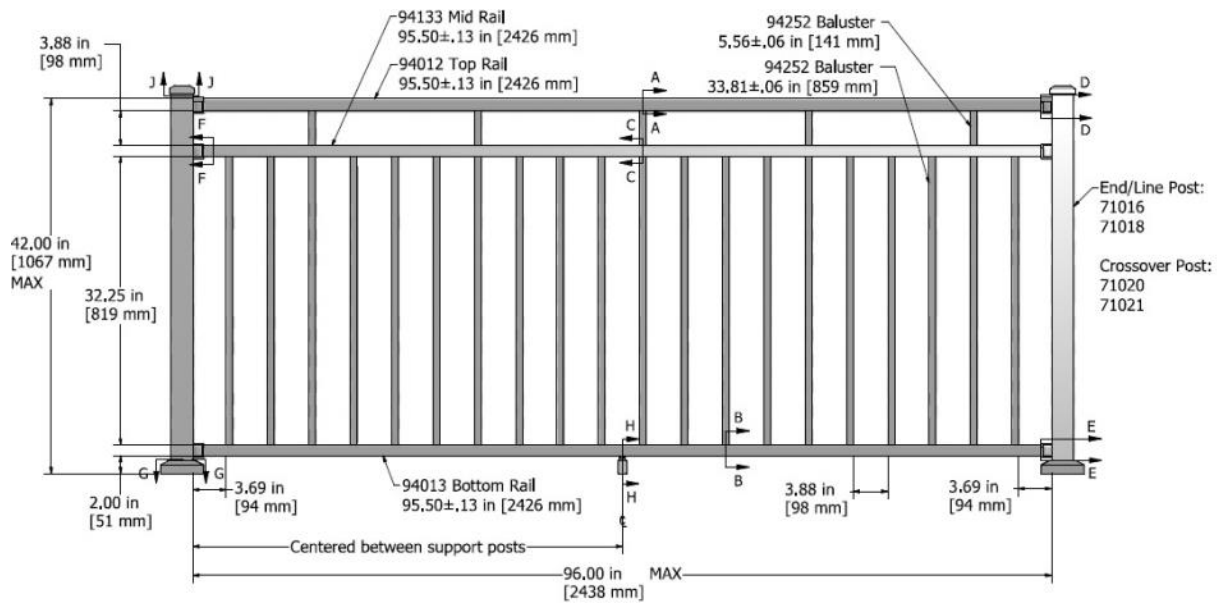

Figure 7  
Westbury® Riviera Series Style C34 Aluminum Railing System

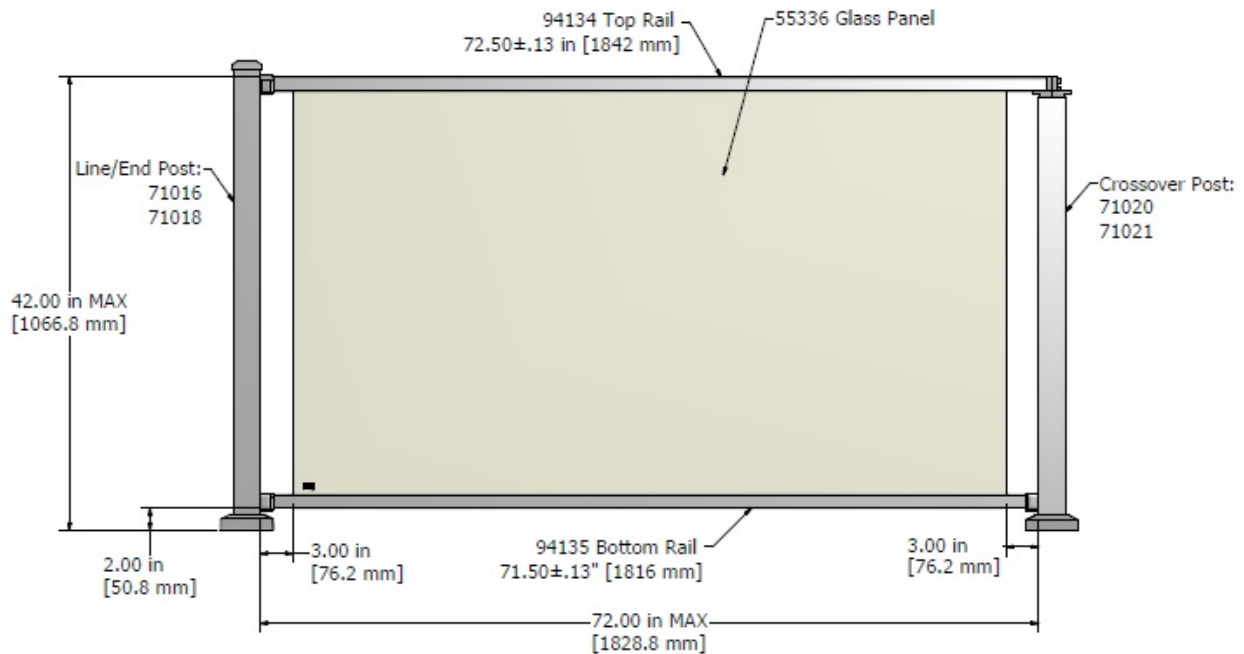
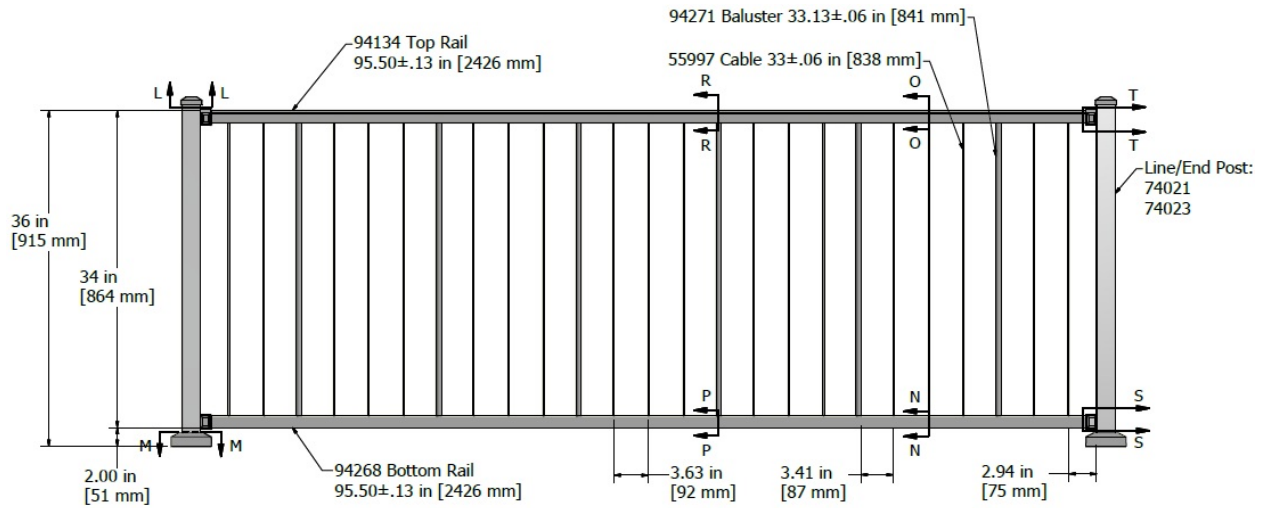
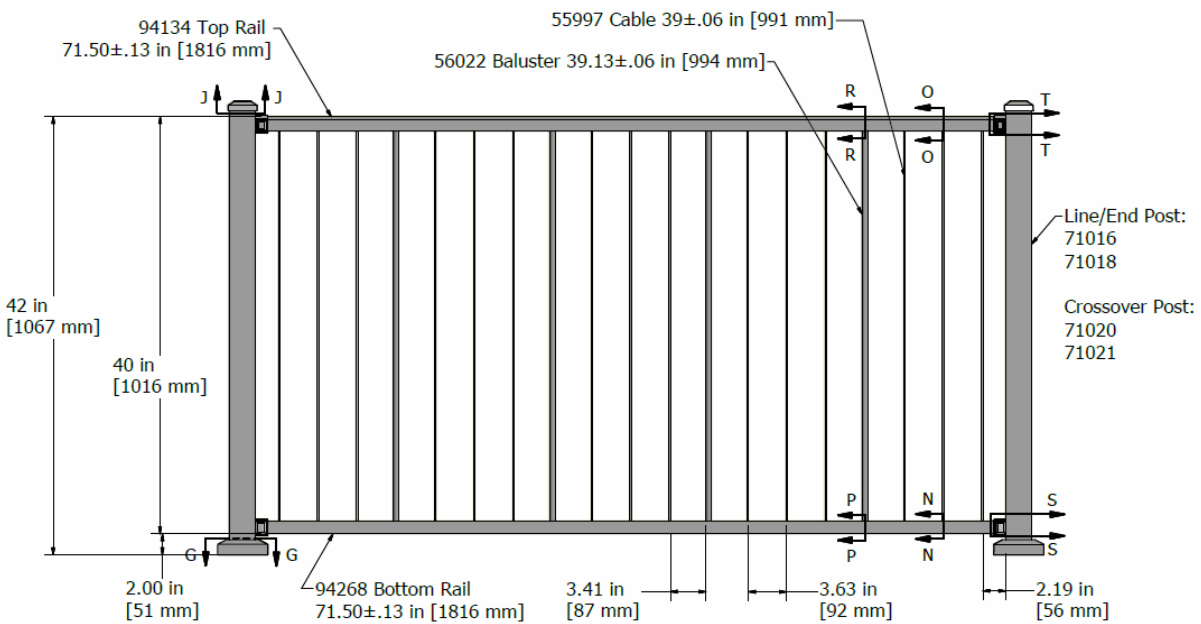

Figure 8  
Westbury® Veranda Series Style C70 Glass Railing System



**Figure 9**  
**Westbury® VertiCable Series Style C80 Aluminum Railing System (36" tall)**



**Figure 10**  
**Westbury® VertiCable Series Style C80 Aluminum Railing System (42" tall)**

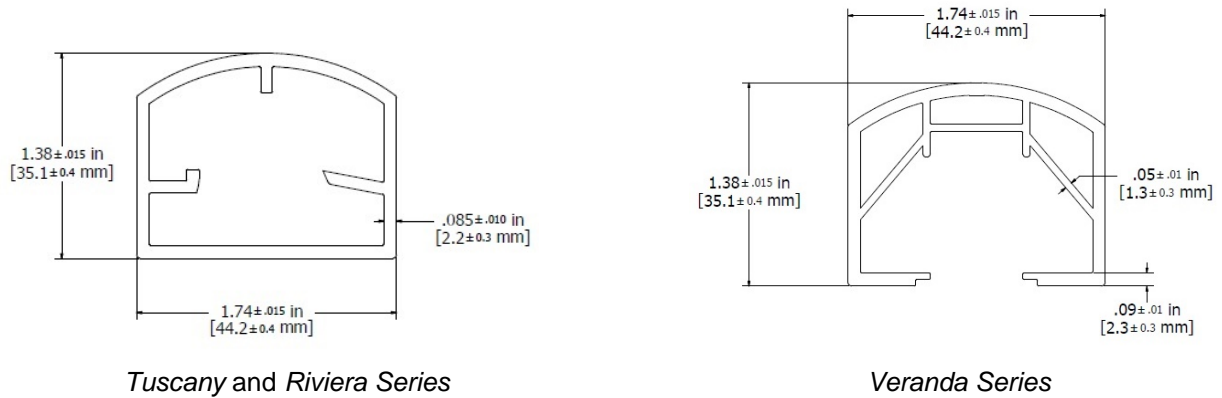

**Figure 11 – Top Rail profiles**

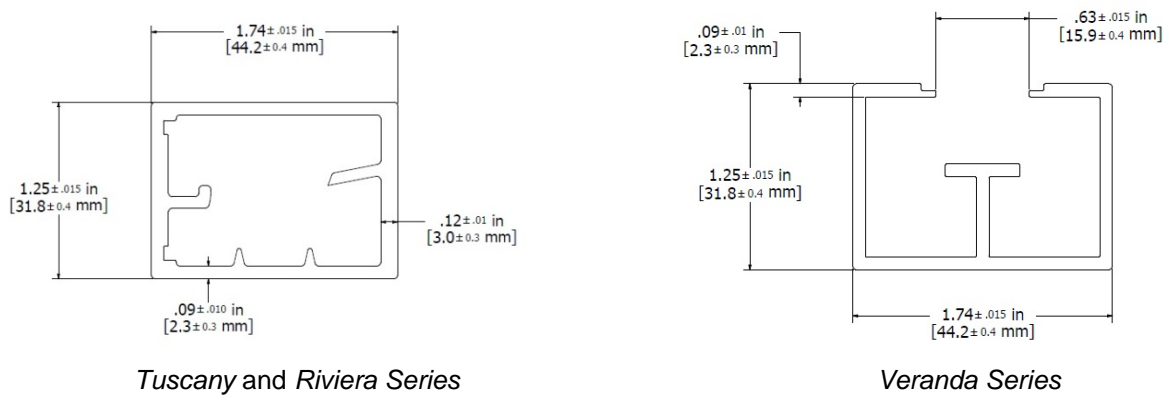

**Figure 12 – Bottom Rail profiles**

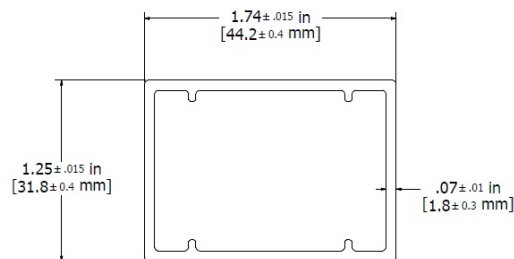

**Figure 13 – Mid-Rail profile (*Riviera Series* only)**

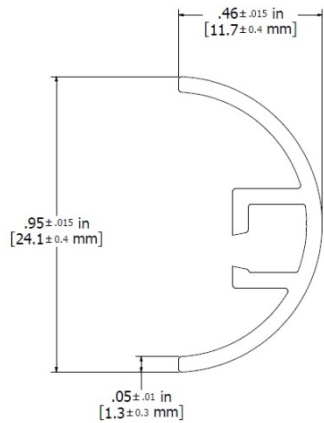

for Top and Bottom Rails

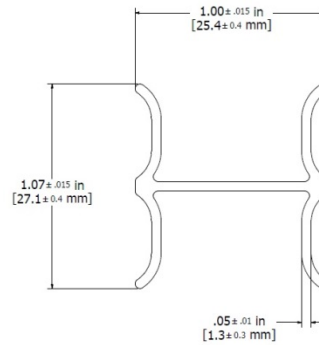

for Mid-Rail

**Figure 14 – *Tuscany* and *Riviera* Series PVC Inserts for aluminum balusters**

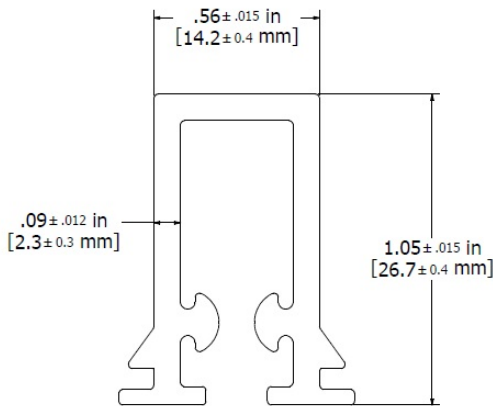

for Top Rails

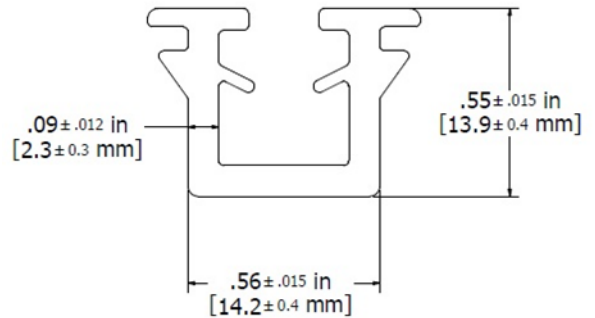

for Bottom Rails

**Figure 15 – *Veranda* Series Rubber Inserts for glass infill**

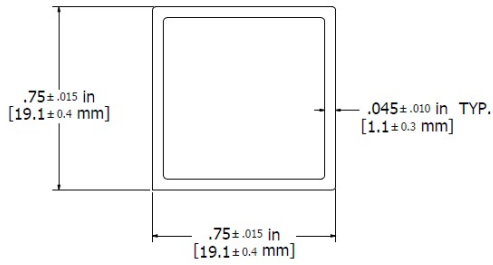
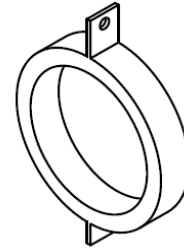
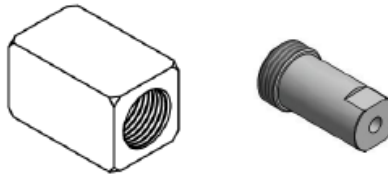
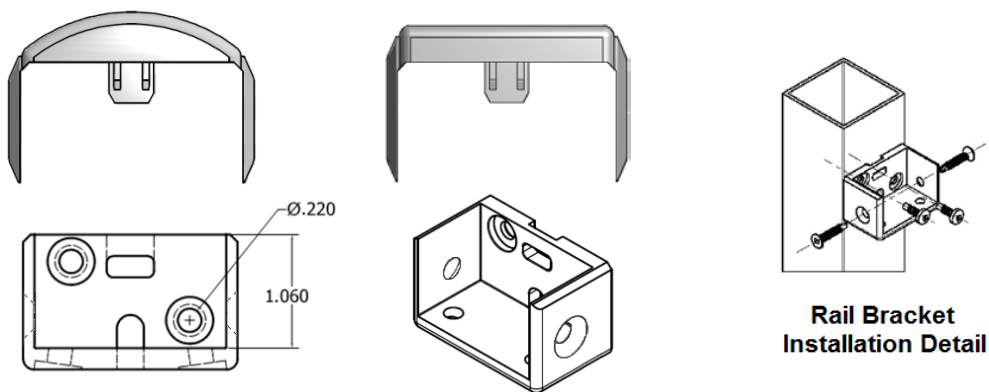
**Figure 16 – Aluminum Balusters**

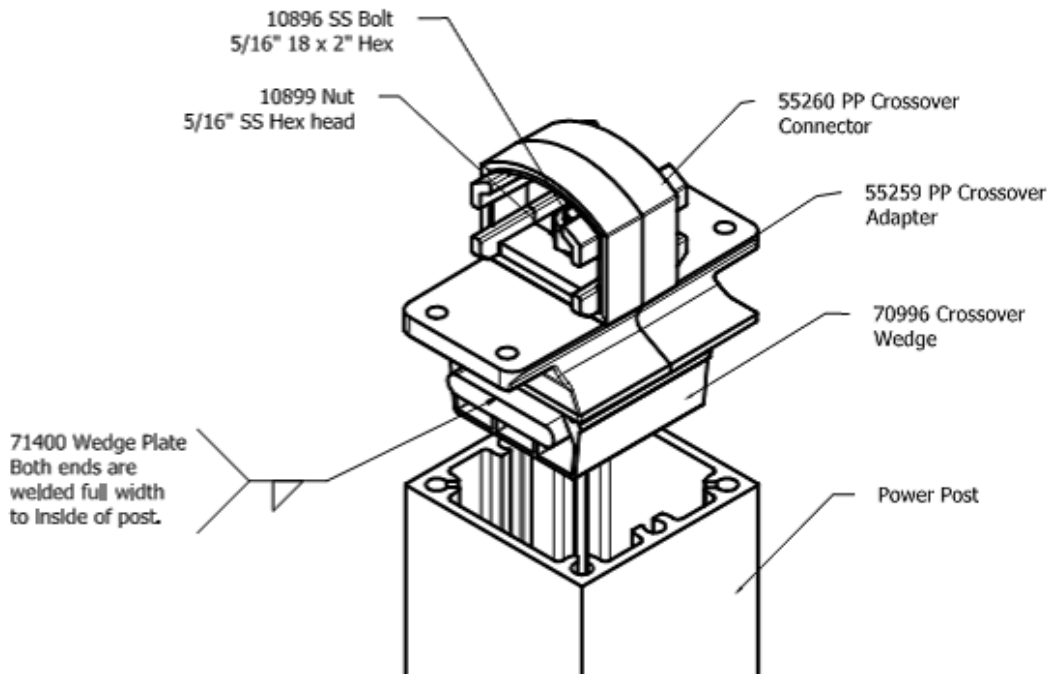
**Figure 17 – Tabbed Ring (*Riviera Series*)**

**Figure 18 - Support Block Components**

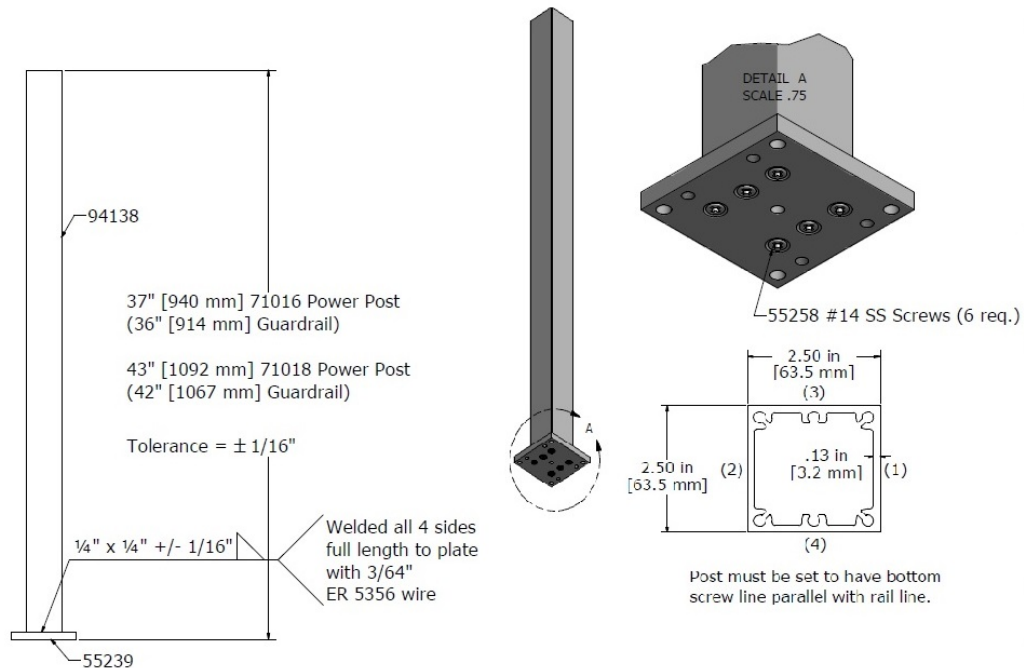
**Figure 19 – Zamak 3 Cast Bracket Components**



**Figure 20 – Power Post Crossover Assembly**



**Figure 21 – 2-1/2" Power Post Assembly**

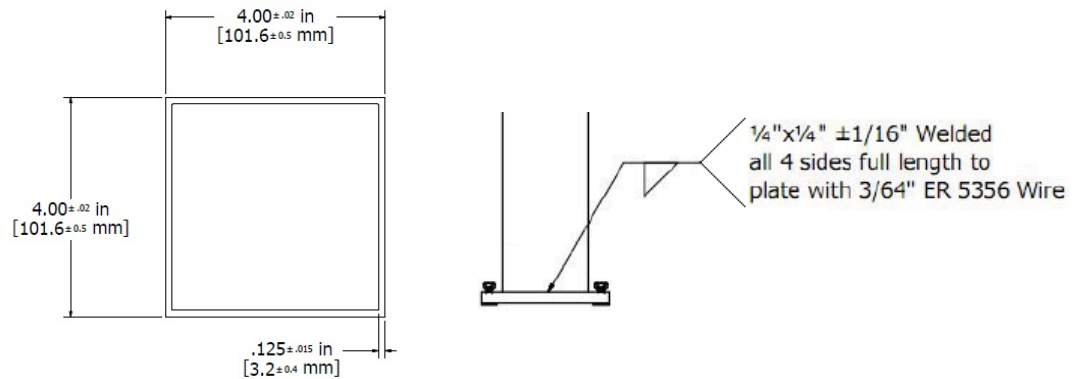

Figure 22 – 4x4 Aluminum Post Assembly

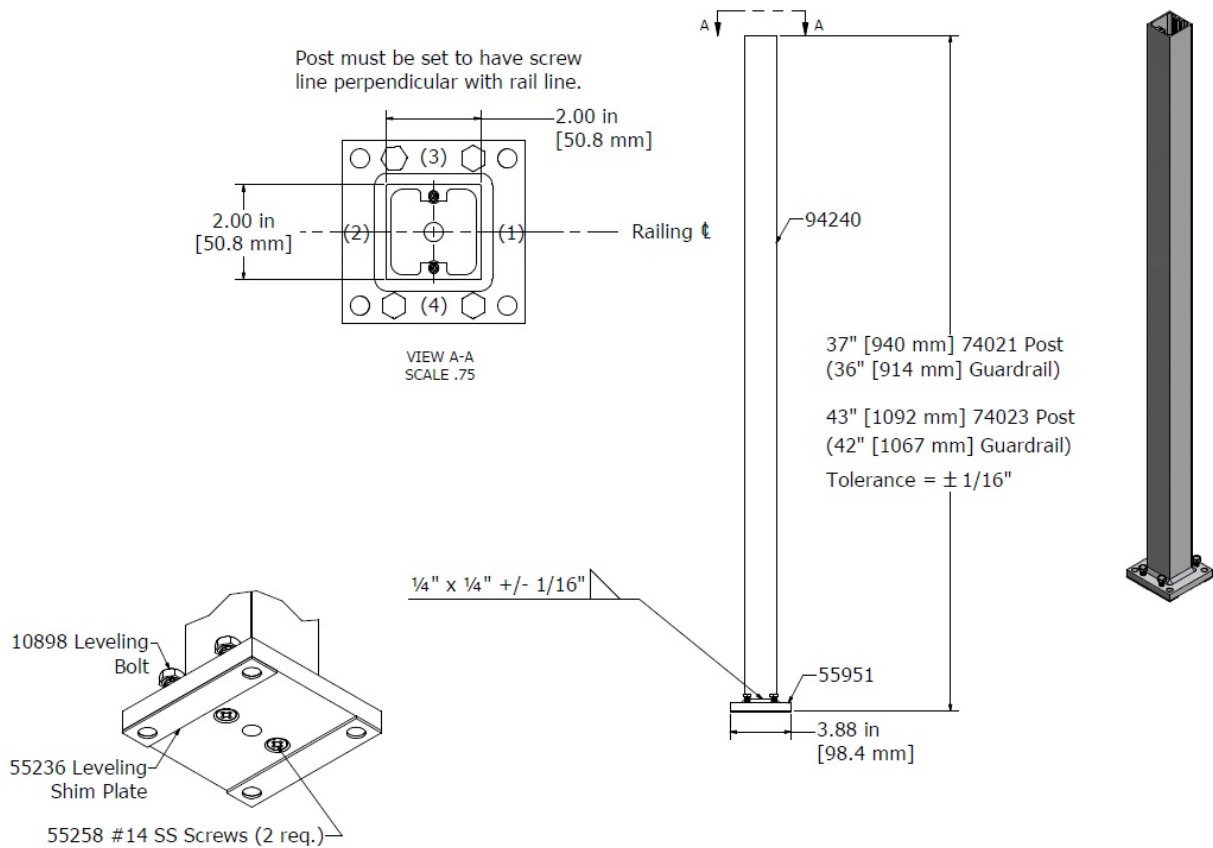
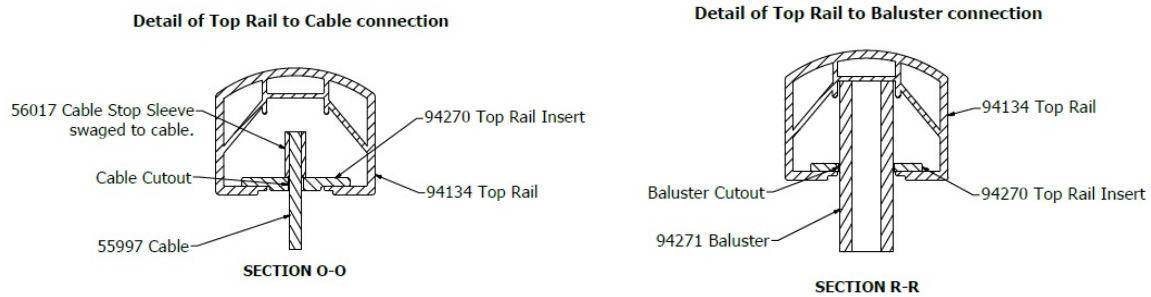

Figure 23 – 2" Aluminum Support Post Assembly



**Figure 24 – Westbury VertiCable Series C80 Top Rail Profiles**



**Figure 25 – Westbury VertiCable Series C80 Bottom Rail Profiles**