

CABLE·RAIL®



DESIGN·RAIL™



CABLE·TRELLIS™



STA-LOK



LIGHTLINE®

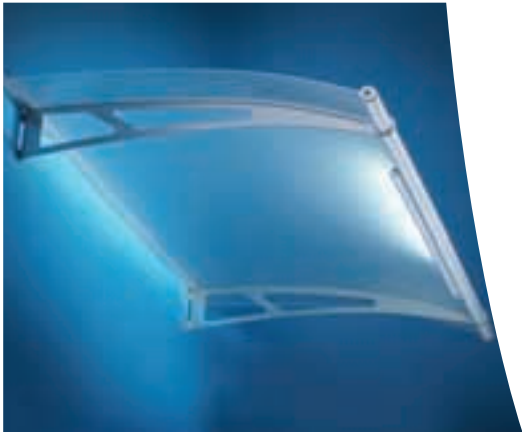

FEENEY
SIXTY YEAR
ANNIVERSARY
★ 1948 - 2008 ★

feeneyarchitectural
PRODUCTS™

CATALOG 2008



feeneyarchitectural P R O D U C T S™

2008 Catalog

INTRODUCTION	4
Environmental	5
CABLERAIL	6
Standard Cable Assemblies	8
Custom Cable Assemblies	20
DESIGNRAIL	36
CABLETRELLIS	48
STA-LOK	56
LIGHTLINE	64

1-800-888-2418
www.feeneyarchitectural.com
© 2008 Feeney Inc. All rights reserved.

feeneyarchitectural P R O D U C T S

Since 1948, Feeney has been manufacturing specialty products for design and construction professionals. Years of experience supplying thousands of projects worldwide have given us the insight and expertise to develop a diverse and innovative line of the highest quality architectural products. Our seasoned, professional staff is always ready to assist with design questions, product selection and technical support.

Our line of Architectural Products includes

CABLE·RAIL®

A wide selection of both standard and custom fabricated stainless steel cable assemblies for use on railings, fences and trellises.

DESIGN·RAIL™

Powder-coated aluminum railing frame systems available in a variety of colors and cap rail styles with glass, picket and cable infill options.

CABLE·TRELLIS®

Wall mounted and freestanding trellis kits with powder-coated aluminum support frames and stainless steel cable and rod plant infill grids.

STA-LOK®

Stainless steel rods, components and assemblies for use in structural and decorative applications.

LIGHTLINE®

Easy-to-install door canopy kits with stainless steel support arms, UV resistant acrylic visor panes and integrated aluminum rain gutters.



Environmental

- All of our architectural products are made from stainless steel and aluminum which are among the most recycled materials. Most of our products contain pre-consumer reclaimed content, and, upon disposal, the materials can be recycled at metal reclamation sites.
- Our products are durable and have long use cycles, thereby reducing replacement costs and maximizing material usage efficiency.
- Our products are very low maintenance and require no treatments, stains, solvents, varnishes or preservatives that may contain contaminating chemicals.
- Our materials and products are strong yet lightweight, using less raw material and allowing easier handling, lower shipping costs and less fuel consumption.
- Our CableTrellis™ kits, as well as CableRail™ cable assemblies, can be used to create energy saving trellis and landscape shading panels and partitions that support cooling foliage in the summer yet allow maximum sunlight and warmth during the dormant winter months.
- Our powder coating facility in Tekamah, NE features a new, state-of-the-art powder coating line that emits no V.O.C.s or heavy metal waste, uses a non-chromium pre-treatment wash, and reclaims 93% of the waste water via a reverse-osmosis membrane filtration system.
- Our manufacturing facility in Oakland, CA utilizes a fully automated, computerized machining center that is programmed to continue running and producing high-precision parts after hours during non-peak electric usage periods and without the need of lighting or technicians.
- Our Oakland plant has over 1000 square feet of photovoltaic solar roof panels that produce as much as 11 kilowatts/hour of sun-generated electricity.

To discuss how our products can help you earn LEED points for your upcoming projects, please give us a call at 1-800-888-2418.

CABLE·RAIL[®]

Stainless Steel Cable Assemblies that Enhance Any Railing and Any View!

Slender CableRail™ cable assemblies are the perfect railing infill alternative to pickets and glass panels. Assemblies are made from beautiful yet weather-tough 316-grade stainless steel with an assortment of cable and attachment hardware options. They're strong, durable, easy to install, low maintenance and virtually invisible. Easy on both the eyes and the view, they make a perfect complement to any railing design, indoors or out.

Our CableRail™ product line is divided into two categories: Standard and Custom.

Standard Cable Assemblies

- Our most popular assemblies
- Sold in pre-cut standardized lengths; easily trimmed to size in the field
- Include special patented QuickConnect-SS™ end fittings for fast installation
- 3 cable sizes, low-profile components, quick to measure, simple to order, easy to install and affordable

Custom Cable Assemblies

- For projects with special installation conditions or design aesthetics
- Wide assortment of cable and fitting options
- Sold as complete assemblies, ready to install, or as individual components for fabricating in the field
- Our experienced sales staff can assist you every step of the way

New! Continuing Education Course

Cable Railing Assemblies: Prefabricated Kits and Custom Design Options. This course is offered online for free through AEC Daily and is registered with American Institute of Architects (AIA), Construction Specifications Institute (CSI) and other associations. Learn all about cable railing assemblies while earning CEU's and Health, Safety and Welfare (HSW) credits. Available at <http://www.aecdaily.com/sponsor/feeney>.

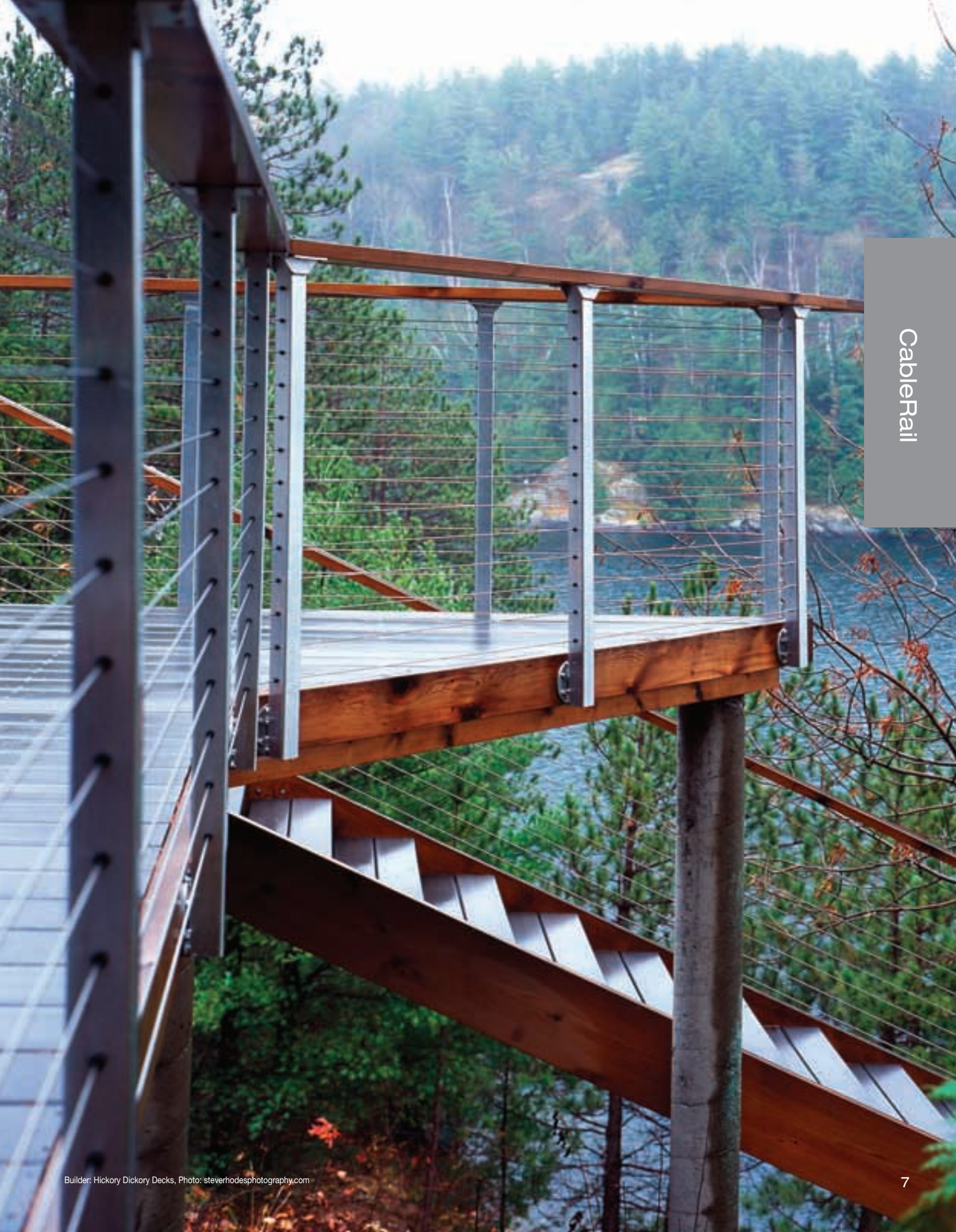

CableRail

CABLE·RAIL[®] Standard

Standard Assemblies Make Measuring, Ordering and Installing a Breeze.

CableRail™ Standard Cable Assemblies are sold in a wide range of standardized pre-cut lengths for easy ordering. There is no wasted time taking precise railing measurements; just select assemblies that are longer than you need and trim any excess in the field. Each assembly includes a pair of special Threaded Terminal and automatic-locking QuickConnect-SS™ attachment fittings that are sleek, simple to use and easy to conceal. The result is not only extremely durable and aesthetic but virtually invisible, allowing beautiful, unimpaired views.

- Made from high-strength, low-maintenance, weather-tough, 316-grade stainless steel
- Available in 1/8", 3/16" and 1/4" diameter cable to complement any railing design
- Sold in a wide range of standard lengths (5 ft to 70 ft in 5-ft increments) that can be trimmed to a finished dimension in the field
- Special automatic-locking QuickConnect-SS™ fittings make installation fast and easy
- May be installed on new or existing wood or metal railing frames in exterior, interior, residential and commercial settings
- Complete installation instructions, frame requirements, 3-part specifications and detail drawings are available at www.cablerail.com
- Materials in stock and ready for fast UPS delivery
- Convenient on-line ordering, available at www.cablerail.com
- Toll-free information and assistance line, *1-800-888-2418*

1-800-888-2418

feeneyarchitectural
P R O D U C T S



Stainless QuickConnect-SS™ fittings make cable projects quicker and easier than ever.

Each assembly comes with a Threaded Terminal fitting pre-attached to one end and a field installed QuickConnect-SS™ fitting for the other end. Simply secure the Threaded Terminal to one end post, lace the free end of the cable through the remaining posts, slip on a QuickConnect-SS™, tension the line, trim the excess and finish with decorative end caps.

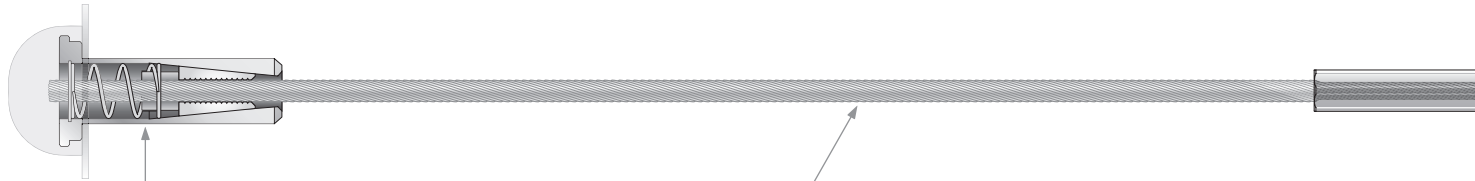

Our unique patented stainless steel QuickConnect-SS™ fitting is attached to the cable in the field without special tools. One-way jaws allow the cable to easily slide through the fitting in one direction but automatically grab and lock-on when the cable is released. Just slip it on, pull the cable tight and cut the excess.



The Cable is 1x19 construction, 316-grade stainless steel for strength, durability and weather protection. Available in 1/8", 3/16" and 1/4" diameters.

1-800-888-2418

feeneyarchitectural
P R O D U C T S



Components that are made to last. All of our cables and swage fittings are manufactured from high-quality 316-grade stainless steel for weather-tough durability, low maintenance and lasting beauty.

The stainless Threaded Terminal fitting is fastened (swaged) to one end of the cable at the factory. It is then attached to an end post using our unique Snug-Grip™ Washer Nut with special gripping threads to help prevent the nut from loosening. Spin the nut to adjust final tension in the line. Available in 7-1/2" length for wood posts and 4-1/4" for metal posts.

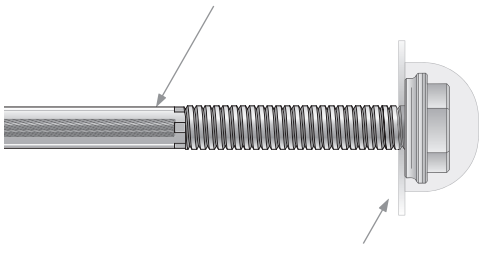

Flat Washers, Snug-Grip™ Washer Nuts and Colored End Caps are all included. Stainless End Caps are also available as an accessory item.



Our cables are designed to be used on your own wood or metal frames in either indoor or outdoor settings. However, we do offer a complete aluminum railing frame system. See details in the DesignRail™ Aluminum Railing Systems section (page 36) or visit www.designrail.com.



CableRail : Standard

Assembly Options

Assembly Lengths

With 4-1/4" Terminal for Metal Posts

With 7-1/2" Terminal for Wood Posts

1/8"

Standard Assemblies

- Our most popular and cost effective cable option
- Perfect for all residential and light commercial projects
- Can be installed on wood or metal frames

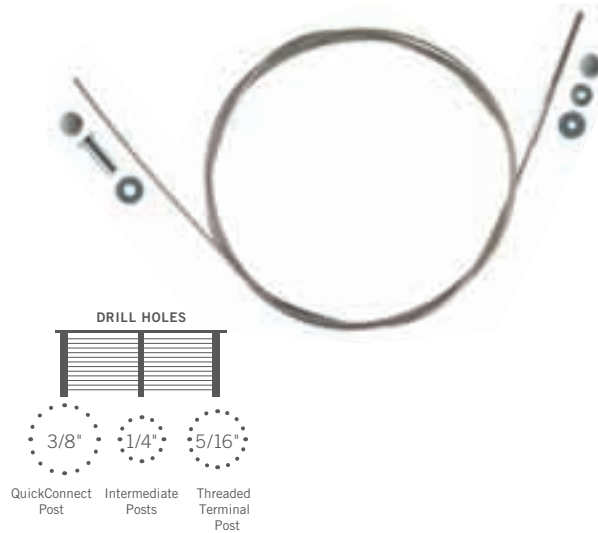

1/8"

5'	6205	6305
10'	6210	6310
15'	6215	6315
20'	6220	6320
25'	6225	6325
30'	6230	6330
35'	6235	6335
40'	6240	6340
45'	6245	6345
50'	6250	6350
55'	6255	6355
60'	6260	6360
65'	6265	6365
70'	6270	6370

3/16"

Standard Assemblies

- Extra durable option for commercial and residential settings
- Can be installed on wood or metal railing frames

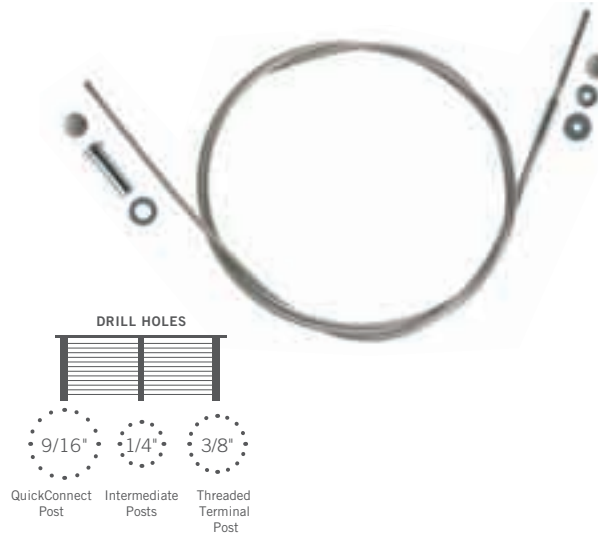

3/16"

5'	6705	6805
10'	6710	6810
15'	6715	6815
20'	6720	6820
25'	6725	6825
30'	6730	6830
35'	6735	6835
40'	6740	6840
45'	6745	6845
50'	6750	6850
55'	6755	6855
60'	6760	6860
65'	6765	6865
70'	6770	6870

1/4"

Standard Assemblies

- Largest, most durable option for high-traffic, high-wear commercial locations
- Or for railing designs where the "look" of a larger cable is desired
- Recommended for metal railing frames only

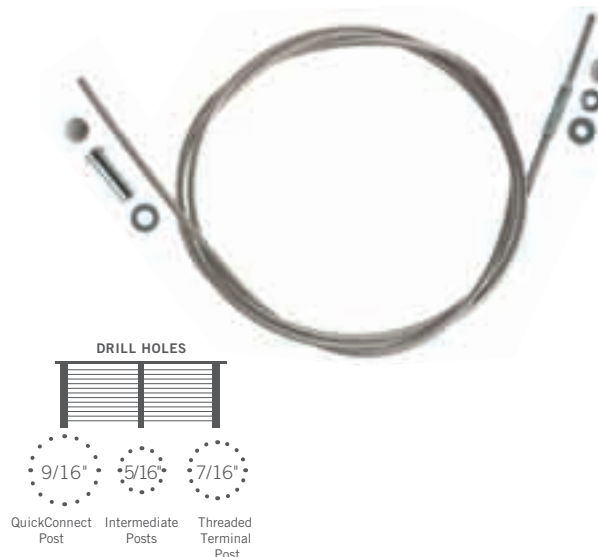

1/4"

5'	6905
10'	6910
15'	6915
20'	6920
25'	6925
30'	6930
35'	6935
40'	6940
45'	6945
50'	6950
55'	6955
60'	6960
65'	6965
70'	6970

Not recommended for wood posts



Assemblies are shipped with a Threaded Terminal fitting attached to one end and a field installed QuickConnect-SS™ fitting for the other end. A Snug-Grip™ Washer Nut, pair of Flat Washers and pair of Colored End Caps are included. Please specify End Cap color when ordering or see Extra Parts (page 14) for Stainless End Cap options.

CableRail : Standard



CABLE·RAIL®

Extra Parts & Tools



STAINLESS END CAPS (316 STAINLESS)

- Decorative option for covering and finishing QuickConnect-SS™ fittings and Snug-Grip™ Washer Nuts

Part#	Style	Size
3372	Dome	3/4" OD x 3/8" H
3373	Crown	3/4" OD x 3/8" H
3374	Chamfer	3/4" OD x 3/8" H



STAINLESS PROTECTOR SLEEVES (316 STAINLESS)

- (Wood posts only) For protecting corner and stair transition posts from cable abrasion
- Use with 1/8" and 3/16" diameter cables
- Fits 1/4" diameter drill holes

Part#	Size
3210	1/4" OD x 7/8" L, 1/2" flange



STAINLESS BEVELED WASHERS (316 STAINLESS)

- For providing a flat bearing surface when attaching fittings at angled stair terminations

Part#	Fitting Used	Size
3792	1/8" QuickConnect-SS™	3/8" ID x 3/4" OD
3799	1/8" Threaded Terminal	9/32" ID x 3/4" OD
3798	3/16" QuickConnect-SS™	9/16" ID x 3/4" OD
3799	3/16" Threaded Terminal	9/32" ID x 3/4" OD
3798	1/4" QuickConnect-SS™	9/16" ID x 3/4" OD
3792	1/4" Threaded Terminal	3/8" ID x 3/4" OD



RUBBER GROMMETS

- (Optional) For adding a finished detail to holes in tubular metal intermediate posts
- Use with 1/8" diameter cable only
- Fits 1/4" diameter drill holes

Part#	Size
3213	1/4" OD x 3/8" L, 7/16" flange



LONG DRILL BITS

- For drilling holes through wood or metal posts

Part#	Size x L	Part#	Size x L
3201	1/4" x 6"	3218	7/16" x 7-1/2"
3203	5/16" x 6-1/2"	*3225	9/16" x 6"
3217	3/8" x 6-1/2"		

*Note: #3225 fits 1/2" chuck



BI-METAL SAW BLADES

- For trimming excess Threaded Terminal threads

Part#	Description
3199	12" Hacksaw blade
5065	6" Reciprocating Saw blade



ABRASIVE DISKS

- For trimming and touching-up exposed cable and threads
- Fits 4-1/2" electric grinders with 7/8" arbor holes

Part#	Description
3219	Cut-Off Disk (designed for cutting stainless)
3220	Grinding Disk



Builder: Copper Iron Designs, Napa CA



CABLE CUTTERS

■ For shearing excess cable

Part#	Cable	Length
2972-pkg	up to 1/8"	7-1/2"
2971	up to 1/4"	13"



CABLE LACING NEEDLE

■ For quickly lacing cable ends through posts without snagging

Part#	Cable Size	Length
3221	1/8"	4-1/2"
3222	3/16"	4-1/2"
3223	1/4"	4-1/2"



ENVIRO-MAGIC® CLEANER

■ For cleaning and protecting cable and hardware
 ■ Non-toxic, biodegradable

Part#	Description
5063	16 oz. spray bottle

HOW TO ORDER CABLERAIL™

- Carefully Review:** Read all of the product information provided in this catalog and on our website www.cablerail.com. If you have questions, please call our sales department for assistance, 1-800-888-2418.
- Select Assembly Lengths:** Locate the cable termination posts where you will start and end your cables. Straight runs should not exceed 70 feet, and runs with bends (2 bends at most) NOT over 40 feet. Select assemblies that are at least one foot longer than the length of your railing sections.
- Determine Quantities:** The number of assemblies depends on your railing design. Remember to space cables no more than 3 inches apart.
- Check Accessories:** Count all the stainless end caps, protector sleeves, grommets, beveled washers and tools you will need.
- Place The Order:** Please call, fax or e-mail us your final list for order processing or order online at www.cablerail.com. Orders ship via UPS.

FREE: 1-800-888-2418
 PH: 1-510-893-9473
 FAX: 1-510-893-9484
 SALES@FEENEYWIRE.COM
 WWW.CABLERAIL.COM

8 Easy Installation Steps.

Complete step-by-step installation instructions and details are available at www.cablerail.com.

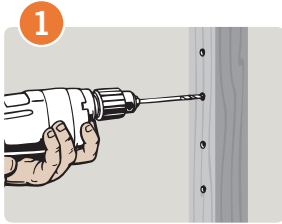

1
Measure, mark and drill holes in all posts.

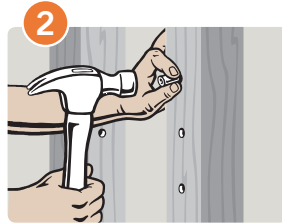

2
Insert Protector Sleeves (wood posts) or Rubber Grommets (tubular metal posts) at necessary locations.

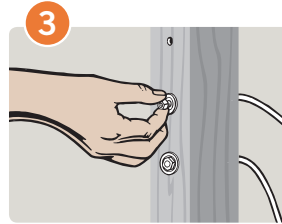

3
Insert the Threaded Terminal into one end termination post and secure with a Snug-Grip™ Washer Nut.

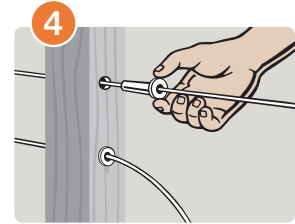

4
Lace the free end of the cable through the remaining posts and slide on a QuickConnect-SS™ fitting.



5
Pull the cable through the QuickConnect-SS™ fitting to remove the excess slack in the line.

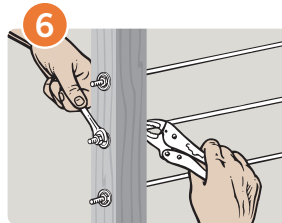

6
Tighten the Snug-Grip™ Washer Nuts to adjust the final tension in the line.

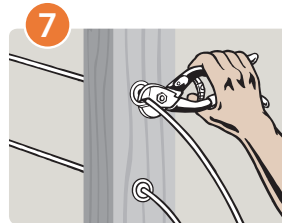

7
Trim the excess threads on the Threaded Terminal and excess cable behind the QuickConnect-SS™.

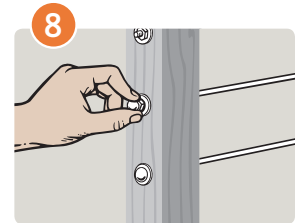

8
Snap on decorative End Caps over the exposed ends of the QuickConnect-SS™ fittings and Snug-Grip™ Washer Nuts.

1-800-888-2418

feeneyarchitectural
PRODUCTS





Architect: Zack de Vito Architecture, San Francisco CA

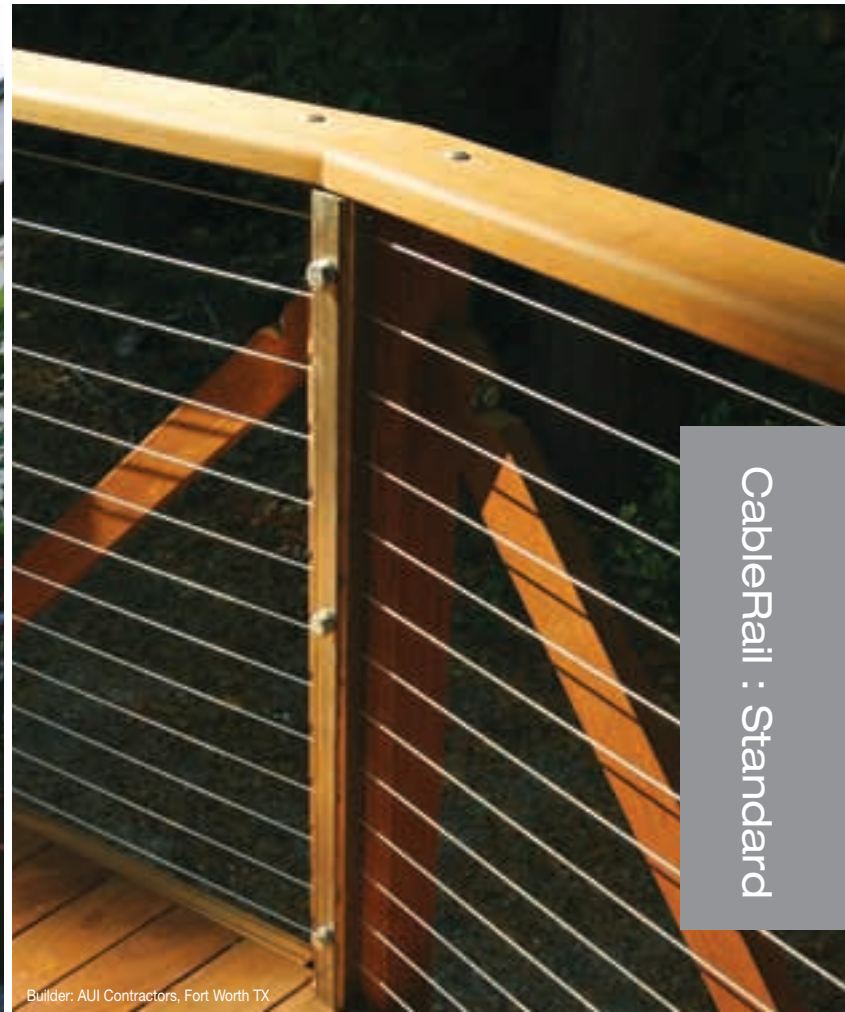

Builder: AJI Contractors, Fort Worth TX

CableRail : Standard

Cables can either terminate or run through corner posts.

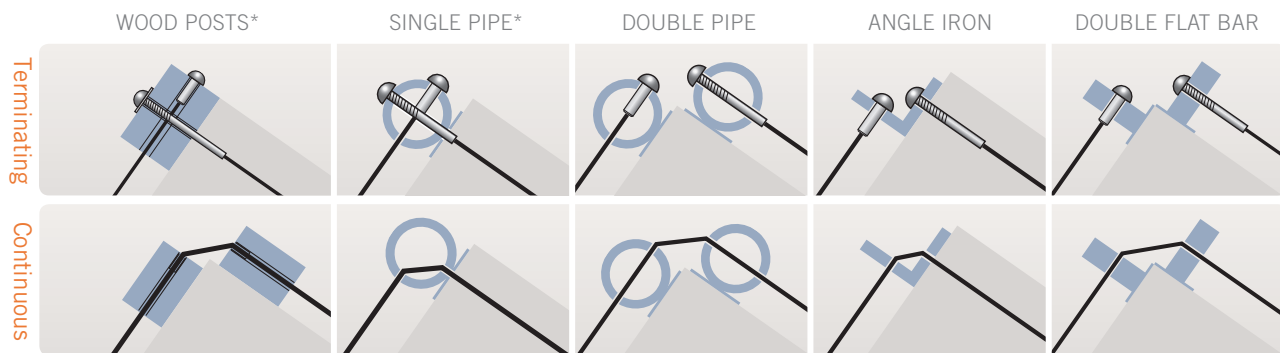

*Offset drill holes at least 1/2" if you choose to have cables terminating at a single wood or pipe post.

CONSTRUCTION CHECKLIST

- Space cables no more than 3 inches apart
- Space posts/verticals no more than 3 feet apart
- Use minimum end/corner post sizes shown on page 34
- Securely fasten all posts and cap rails
- Carefully plan all termination and corner posts for proper clearance, positioning, and maximum cable run lengths

IMPORTANT NOTES

- Since building codes vary by state, county and city, our recommendations may not comply with code requirements in all areas. Always consult with your local building department before starting your project.
- CableRail™ cable assemblies and fittings are designed for use on railings, fences and trellises only. They should never be used for lifting, hanging or high load applications.

Railing Frame Requirements

It is very important that your railing frames be designed and built strongly enough to support the tension of properly installed cables, which is a load in excess of 300 lbs for each cable. Frames can also be designed to use cables more efficiently, thereby reducing the total quantity of cable assemblies needed and the overall cost.

Special consideration must be given to the following:

- Size of the end and corner posts
- Spacing of posts from walls
- Spacing between posts and verticals
- Secure attachment of posts to the deck structure and cap rail
- Height of the railing
- Spacing of the cables

For more information on how to properly prepare your railing frames, please see the Frame Requirements section on pages 34 & 35 of this catalog. Visit our website www.cablerail.com for the most complete details.



10 YEAR LIMITED WARRANTY

Feeney Inc (Feeney) warrants that all CableRail™ stainless steel cable and connectors shall be free from defects in material and workmanship under normal use, conditions, installation and maintenance in accordance with product specifications for ten (10) years from date of purchase. The complete text of this warranty is available on our website www.cablerail.com.

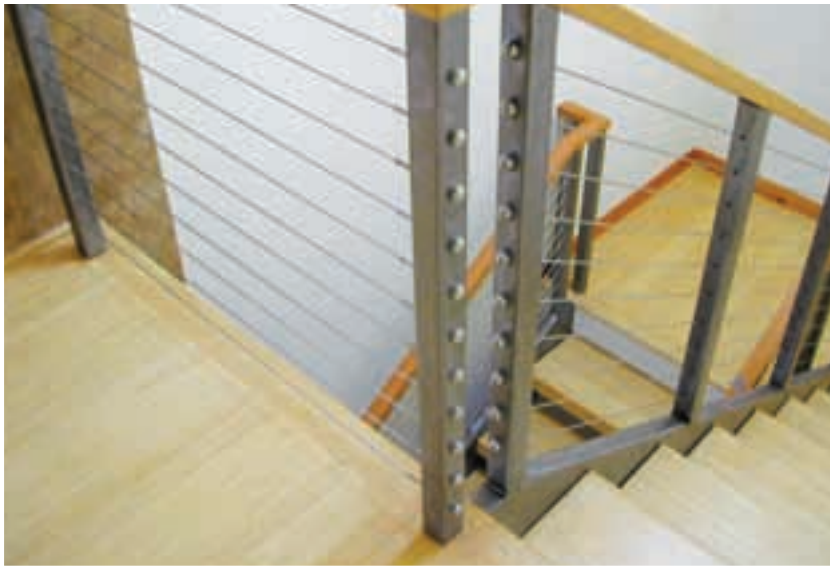

Photo: William Hopkins Photography

A FEW WORDS ABOUT STAINLESS STEEL

The protective chromium oxide film on the surface of stainless steel gives it superior corrosion resistance. Properly maintained stainless steel provides excellent luster, strength and durability. In most applications, stainless steel will not rust or stain even after years of service, but it is NOT rust or stain proof. When stainless comes in contact with chloride salts, sulfides or other rusting metals, it can discolor or even rust and corrode. With proper care and maintenance, however, stainless steel can remain beautiful and functional for years to come, even when exposed to marine environments, polluted surroundings, salted highways, or other corrosive elements. For complete care and maintenance instructions, please visit www.cablerail.com.



CableRail : Standard

CABLE·RAIL[®] Custom

Architectural Hardware That Anticipates Any Cable Design.

Projects with special installation conditions or design considerations may require certain styles of cable and fittings not addressed by our CableRail™ Standard Cable Assemblies. To fulfill those specific design and function needs, Feeney offers a wide assortment of cables, turnbuckles, terminals, adjusters and fixed ends for custom assemblies. You can either order individual components and hand crimp your own assemblies, or let us fabricate them for you, complete and ready to install.

- Wide selection of cables and fittings to meet any design requirement
- Made from high-quality 316-grade stainless steel with a tumbled satin finish for weather-tough durability, low maintenance and lasting beauty
- Versatile uses include railings, trellises, fences, exteriors, interiors, residential, commercial
- Assemblies may be fabricated at your job site or in our factory, ready to install
- Detail drawings and 3-part specifications available at www.cablerail.com
- Materials in stock and ready for fast UPS delivery
- Toll-free design assistance and technical support line, *1-800-888-2418*

1-800-888-2418

feeneyarchitectural
P R O D U C T S



CableRail : Custom

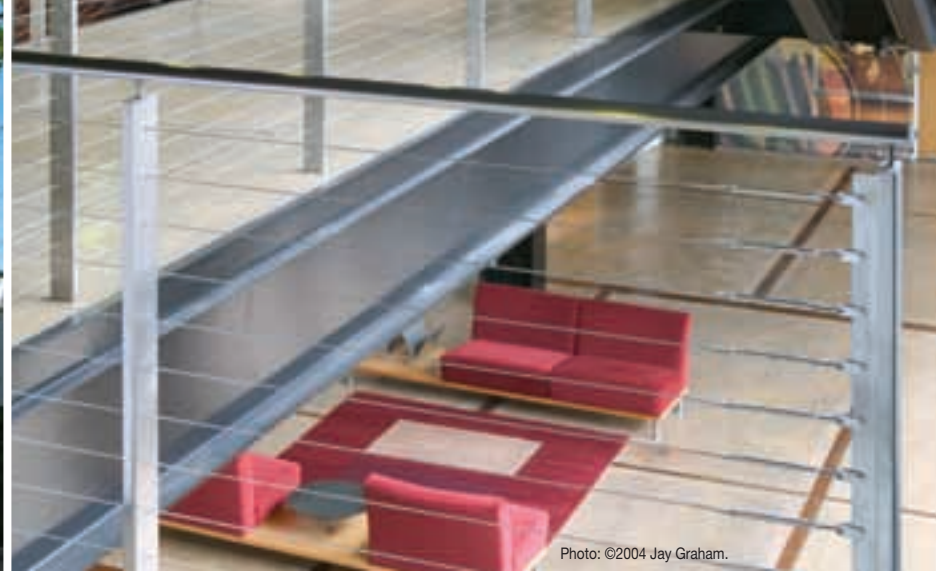

Photo: ©2004 Jay Graham.

Custom Cable Assemblies

Fittings can be attached to the cable either at our factory or in the field.

Machine Swaging (swā'j'ing)

M

Machine swage fittings are attached to the cable at our factory using a hydraulic cold forming press. The swage shank portion of the fitting is pressed on to the end of the cable and has a uniform hexagonal shape when finished. Assemblies using Machine Swage type fittings are fabricated to your exact lengths in our factory and then shipped ready to install.

CableCrimp™ Hand swaging

C

CableCrimp™ style fittings are attached to the cable by hand in the field using a special CableCrimp™ Crimper tool (#3742). After proper crimping, the fitting will display several evenly spaced compression marks where the tool was engaged. Most 1/8" and 3/16" cable fittings are available in CableCrimp™ styles.

All of our cables and swage fittings are manufactured from high-quality 316-grade stainless steel with a tumbled satin finish for weather-tough durability, low maintenance and lasting beauty.



CABLE·RAIL™

1-800-888-2418

feeneyarchitectural
PRODUCTS

316-GRADE STAINLESS STEEL Cable

The usual choices for railings and architectural applications are uncoated 1/8", 3/16" and 1/4" diameter 1x19 and 7x7 cables of 316-grade stainless steel. The reasons: versatility, aesthetics, low maintenance, longevity and high abrasion resistance.

Part #	CableØ	Construction
4140	1/8"	1x19
4126	1/8"	7x7
4117	3/16"	1x19
4129	3/16"	7x7
4118	1/4"	1x19
4200	1/4"	7x7

1X19 CONSTRUCTION CABLES

- 19 individual wires twisted into a single, semi-flexible strand
- Excellent for railings, fences and trellises with straight runs or slight bends

7X7 CONSTRUCTION CABLES

- 49 individual wires woven into a flexible strand
- Best for conditions that require tighter bends or for designs where a more woven wire appearance is desired

Also available: clear and colored vinyl and nylon coated cables and a wide assortment of other stainless, galvanized and bright steel cables and wire ropes. For details, call our toll-free information line, 1-800-888-2418.

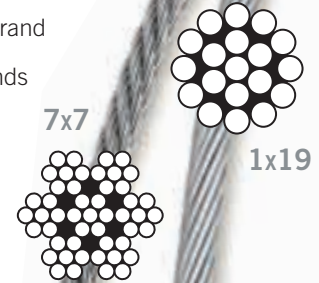

CableRail : Custom



Cable Fittings

THERE ARE TWO TYPES OF CABLE FITTINGS:

TENSION ADJUSTMENT FITTINGS (TAF)

- Include Threaded Terminals, Turnbuckles and Adjusters that are used to tighten the cable lines
- Tension is adjusted by tightening the nut on the Threaded Terminals, spinning the tubular body of the Turnbuckles or rotating the bolt on the Adjusters
- Tension Adjustment fittings can be paired with either a Fixed End or another Tension Adjustment Fitting

FIXED ENDS (FE)

- Non-adjustable end termination fittings, sometimes referred to as “dead ends”
- Have no tensioning capabilities
- Each Fixed End must be paired with at least one Tension Adjustment Fitting

Every cable assembly must have at least one Tension Adjustment Fitting in order to tension the line. The diagram below shows the 3 common fitting positions.

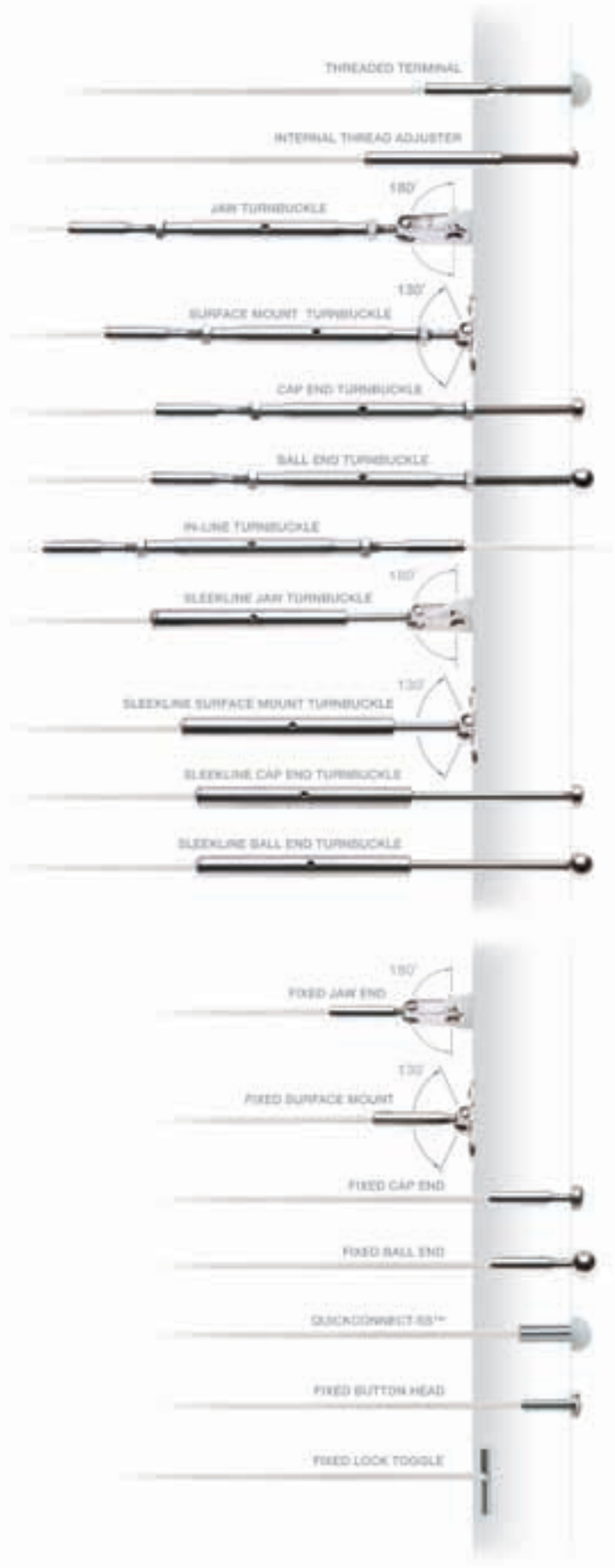
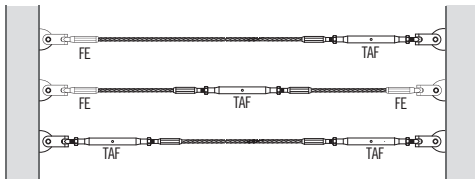

1-800-888-2418

feeneyarchitectural
PRODUCTS



316-GRADE STAINLESS STEEL Fixed Ends

These stainless steel, non-adjustable end termination fittings have no tensioning capability. Therefore, each must be paired with at least one of the Tension Adjustment Fittings.

FIXED JAW END

- Attaches quickly to eyebolts, eyelets, or drilled tabs using a removable clevis pin
- 180° pivoting makes these ideal for angled stair terminations
- Typically paired with a Jaw Turnbuckle

Part#	Swage	CableØ	PinØ	TL	G	L	Pin DrillØ
3288	M	1/8"	1/4"	15/16"	5/16"	2-7/8"	5/16"
3331	M	3/16"	1/4"	15/16"	5/16"	3"	5/16"
3336	M	1/4"	5/16"	1"	3/8"	4-1/8"	3/8"
*3279	C	1/8"	1/4"	15/16"	5/16"	3-3/4"	5/16"
3280	C	3/16"	1/4"	15/16"	5/16"	3-3/4"	5/16"

* #3279 same as #3280 but includes insert sleeve for crimping onto 1/8" cable

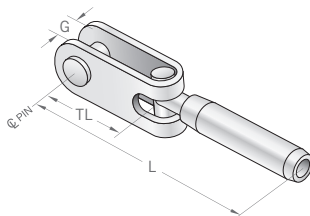

Note on charts: **DrillØ** is the recommended drill hole size for attaching the fittings to the end posts. Drill hole sizes for all other intermediate posts may differ; please call to confirm correct drill sizes.

FIXED SURFACE MOUNT

- Attaches to the face of the end post using lag screws or bolts (#3183 or #3322)
- 130° pivoting allows for easy angled stair terminations
- Typically paired with a Surface Mount Turnbuckle

Part#	Swage	CableØ	EØ	H	W	L
3281	M	1/8"	1/4"	1-5/16"	5/8"	2-1/8"
3284	M	3/16"	1/4"	1-5/16"	5/8"	2-1/4"
3337	M	1/4"	5/16"	1-1/2"	3/4"	3-1/4"
*3333	C	1/8"	1/4"	1-5/16"	5/8"	3"
3334	C	3/16"	1/4"	1-5/16"	5/8"	3"

* #3333 same as #3334 but includes insert sleeve for crimping onto 1/8" cable

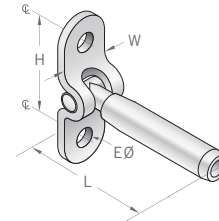

FIXED CAP END

- Inserts through a drill hole in the end post and attaches with a screw-on end cap
- Use beveled washers (#3793) for angled stair terminations and flat washers (page 31) for added bearing surface on wood posts
- Typically paired with a Cap End Turnbuckle

Part#	Swage	CableØ	Thread	CØ	CT	L	DrillØ
3315	M	1/8"	1/4-28RH	9/16"	5/16"	1-3/8"	5/16"
3316	M	3/16"	1/4-28RH	9/16"	5/16"	1-7/8"	3/8"
3317	M	1/4"	5/16-24RH	9/16"	5/16"	2-1/8"	7/16"
3318	C	1/8"	1/4-28RH	9/16"	5/16"	2"	5/16"
3319	C	3/16"	1/4-28RH	9/16"	5/16"	2-3/8"	3/8"

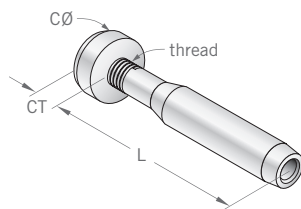

FIXED BALL END

- Inserts through a drill hole or slot in the end post and attaches with a screw-on ball
- Ball pivots to allow angled stair terminations without beveled washers
- Typically paired with a Ball End Turnbuckle

Part#	Swage	CableØ	Thread	DØ	L	DrillØ*
3352	M	1/8"	1/4-28RH	5/8"	1-1/4"	5/16"
3353	M	3/16"	1/4-28RH	5/8"	1-3/4"	3/8"
3354	M	1/4"	5/16-24RH	5/8"	2"	7/16"
3355	C	1/8"	1/4-28RH	5/8"	1-7/8"	5/16"
3356	C	3/16"	1/4-28RH	5/8"	2-1/4"	3/8"

* Ball can be slightly recessed into post by counterboring with 9/16" drill.

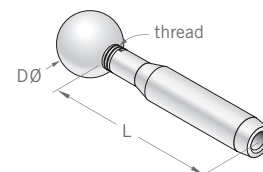

M Machine Swage
C CableCrimp™ Hand Swage
 See pages 30 & 31 for accessory items and tools

316-GRADE STAINLESS STEEL Fixed Ends

QUICKCONNECT-SS™ (PATENTED)

- Fits into a hole drilled through the end post, and the lip rests against the outside face of the post
- One-way jaws allow cable to pass through the fitting in one direction and lock automatically when cable is released; no tools needed
- Use beveled washers for angled stair terminations and flat washers (page 31) for added bearing surface on wood posts
- Finish with stainless or colored End Caps
- Can be paired with any Tension Adjustment Fitting

Note on charts: DrillØ is the recommended drill hole size for attaching the fittings to the end posts. Drill hole sizes for all other intermediate posts may differ. Please call to confirm correct drill sizes.

Part#	Swage	CableØ	BØ	CØ	L	DrillØ
3146	Self-Lock	1/8"	3/8"	5/8"	1-1/8"	3/8"
3147	Self-Lock	3/16"	17/32"	3/4"	1-5/8"	9/16"
3148	Self-Lock	1/4"	17/32"	3/4"	1-5/8"	9/16"

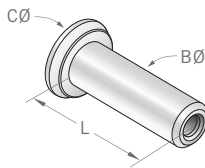

FIXED BUTTON HEAD

- Single piece fitting with a non-removable, low-profile rounded head
- Fits into a hole drilled through the end post, and the head rests against the outside face of the post
- Use beveled washers (#3791) for angled stair terminations and flat washers (page 31) for added bearing surface on wood posts
- Typically paired with another Fixed Button Head plus an In-Line Turnbuckle

Part#	Swage	CableØ	CØ	CT	L	DrillØ
3287	M	1/8"	7/16"	1/8"	1"	9/32"

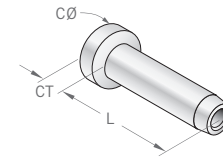

FIXED LOCK TOGGLE

- Used on tubular metal end posts where the design only allows for penetration of one side of the post
- The fitting passes through a drill hole and toggles into a locked position inside the post, leaving no exposed hardware
- Will accommodate angled stair conditions without beveled washers
- Typically paired with another Fixed Lock Toggle plus an In-Line Turnbuckle

Part#	Swage	CableØ	L	SBØ	DrillØ
3169	M	1/8"	1-1/2"	1/4"	5/16"
3164	C	1/8"	1-1/2"	7/32"	5/16"

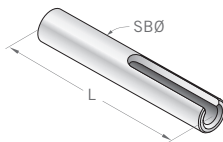

M Machine Swage

C CableCrimp™ Hand Swage

See pages 30 & 31 for accessory items and tools

1-800-888-2418

feeneyarchitectural
PRODUCTS



316-GRADE STAINLESS STEEL Tension Adjustment Fittings

Stainless steel Threaded Terminals, Turnbuckles and Adjusters provide tension to the cable lines. Tension is adjusted by tightening the nuts on the Threaded Terminals, spinning the tubular bodies on the Turnbuckles or rotating the bolt on the Adjusters. Every cable assembly must include at least one Tension Adjustment Fitting.

THREADED TERMINAL

- Inserts through a drill hole in the end post and attaches with a washer and nuts (sold separately, pages 30 & 31)
- Use beveled washers for angled stair terminations and flat washers (page 31) for added bearing surface on wood posts
- Typically paired with another Threaded Terminal

Part#	Swage	CableØ	Thread	T	L	SBØ	DrillØ
3191	M	1/8"	1/4-20RH	2-3/8"	4-1/4"	1/4"	5/16"
3193	M	1/8"	1/4-20RH	2-7/8"	7-1/2"	1/4"	5/16"
3168	M	1/8"	1/4-20RH	1"	2-1/2"	1/4"	5/16"
3197	M	1/8"	1/4-28RH	2-3/8"	4-1/4"	1/4"	5/16"
3250	M	1/8"	1/4-28LH	2-1/2"	3-3/4"	1/4"	5/16"
3253	M	3/16"	1/4-20RH	2-1/2"	4-1/4"	11/32"	3/8"
3256	M	3/16"	1/4-20RH	2-7/8"	7-1/2"	11/32"	3/8"
3198	M	3/16"	1/4-28RH	2-1/2"	4-1/4"	11/32"	3/8"
3254	M	3/16"	1/4-28LH	2-1/2"	4-1/4"	11/32"	3/8"
5050	M	1/4"	5/16-24RH	2-1/2"	4-1/2"	7/16"	7/16"
3249	M	1/4"	5/16-24LH	2-3/4"	4-3/4"	7/16"	7/16"
3260	C	1/8"	1/4-20RH	2-1/2"	4-1/2"	7/32"	5/16"
3251	C	1/8"	1/4-20RH	2-7/8"	7-1/2"	7/32"	5/16"
3190	C	1/8"	1/4-28RH	2-1/2"	4-1/2"	7/32"	5/16"
3247	C	1/8"	1/4-28LH	2-1/2"	4-1/2"	7/32"	5/16"
3263	C	3/16"	1/4-20RH	2-1/2"	4-3/4"	9/32"	3/8"
3264	C	3/16"	1/4-20RH	2-7/8"	7-1/2"	9/32"	3/8"
3192	C	3/16"	1/4-28RH	2-1/2"	4-3/4"	9/32"	3/8"
3248	C	3/16"	1/4-28LH	2-1/2"	4-3/4"	9/32"	3/8"

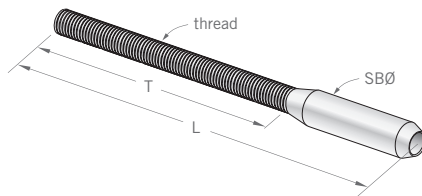

Note on charts: **DrillØ** is the recommended drill hole size for attaching the fittings to the end posts. Drill hole sizes for all other intermediate posts may differ. Please call to confirm correct drill sizes.

IN-LINE TURNBUCKLE

- Used in the middle of a cable assembly for additional tensioning on long runs or where end tensioning is not feasible or desired
- Can be combined with any Tension Adjustment Fitting or Fixed End

Part#	Swage	CableØ	Thread	L close (open)
3289	M	1/8"	1/4-28	7-1/2" (10-1/2")
3731	M	3/16"	1/4-28	8-1/2" (11-1/2")
3291	M	1/4"	5/16-24	9-1/2" (13-1/4")
3292	C	1/8"	1/4-28	9" (12")
3293	C	3/16"	1/4-28	9-1/2" (12-1/2")

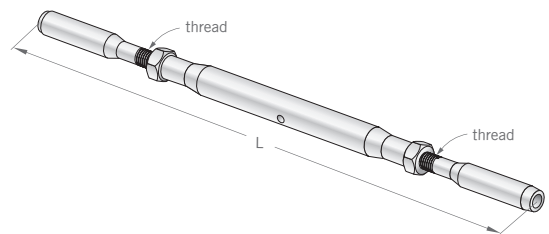

INTERNAL THREAD ADJUSTER

- Inserts through a drill hole in end post and attaches using a bolt and washer (included)
- Use beveled washer (#3791) for angled stair terminations
- Typically paired with another Internal Thread Adjuster

Part#	Swage	CableØ	Thread	WØ	L close (open)	SBØ	DrillØ
3266-1.5	M	1/8"	10-24RH	7/16"	2-3/4" (3-3/4")	1/4"	5/16"
3266-2	M	1/8"	10-24RH	7/16"	3-1/4" (4-1/4")	1/4"	5/16"
3266-3	M	1/8"	10-24RH	7/16"	4-1/4" (5-1/4")	1/4"	5/16"
3267-1.5	M	3/16"	1/4-20RH	11/16"	3-1/4" (4-1/4")	11/32"	3/8"
3267-2	M	3/16"	1/4-20RH	11/16"	3-3/4" (4-3/4")	11/32"	3/8"
3267-3	M	3/16"	1/4-20RH	11/16"	4-3/4" (5-3/4")	11/32"	3/8"

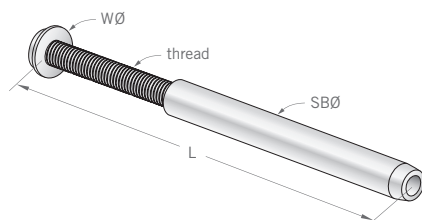

M Machine Swage
C CableCrimp™ Hand Swage
See pages 30 & 31 for accessory items and tools

316-GRADE STAINLESS STEEL Tension Adjustment Fittings

JAW TURNBUCKLE

- Attaches to fixed eyebolts, eyelets, or drilled tabs using a removable clevis pin
- 180 degree pivoting makes these ideal for angled stair terminations
- Typically paired with a Fixed Jaw End or another Jaw Turnbuckle

Part#	Swage	CableØ	Thread	PinØ	G	L close (open)	Pin DrillØ
3270	M	1/8"	1/4-28	1/4"	5/16"	7-3/4" (10-3/4")	5/16"
3271	M	3/16"	1/4-28	1/4"	5/16"	8-1/4" (11-1/4")	5/16"
3332	M	1/4"	5/16-24	5/16"	3/8"	9-1/4" (13")	3/8"
3268	C	1/8"	1/4-28	1/4"	5/16"	8-1/2" (11-1/2")	5/16"
3269	C	3/16"	1/4-28	1/4"	5/16"	8-3/4" (11-3/4")	5/16"

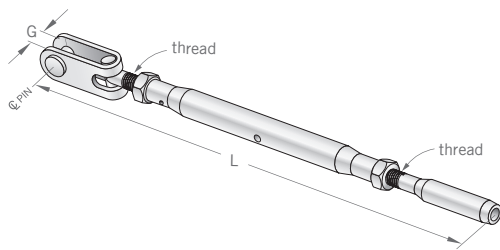

Note on charts: **DrillØ** is the recommended drill hole size for attaching the fittings to the end posts. Drill hole sizes for all other intermediate posts may differ. Please call to confirm correct drill sizes.

SURFACE MOUNT TURNBUCKLE

- Attaches to face of the end post using lag screws or bolts (#3183 or #3322)
- 130 degree pivoting allows for angled stair terminations
- Typically paired with a Fixed Surface Mount or another Surface Mount Turnbuckle

Part#	Swage	CableØ	Thread	EØ	H	W	L close (open)
3278	M	1/8"	1/4-28	1/4"	1-5/16"	5/8"	7" (10")
3277	M	3/16"	1/4-28	1/4"	1-5/16"	5/8"	7-1/2" (10-1/2")
3338	M	1/4"	5/16-24	5/16"	1-1/2"	3/4"	8-1/4" (12")
3275	C	1/8"	1/4-28	1/4"	1-5/16"	5/8"	7-3/4" (10-3/4")
3276	C	3/16"	1/4-28	1/4"	1-5/16"	5/8"	8" (11")

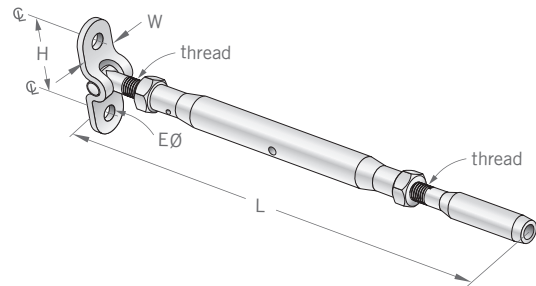

CAP END TURNBUCKLE

- Inserts through a drill hole in the end post and attaches with a screw-on end cap
- Use beveled washer (#3793) for angled stair terminations and flat washers (page 31) for added bearing surface on wood posts
- Typically paired with a Fixed Cap End or another Cap End Turnbuckle

Part#	Swage	CableØ	Thread	CØ	A* close	L close (open)	DrillØ
3325	M	1/8"	1/4-28	9/16"	1-3/8"	7-3/4" (10-3/4")	5/16"
3326	M	3/16"	1/4-28	9/16"	1-3/8"	8-1/4" (11-1/4")	5/16"
3327	M	1/4"	5/16-24	9/16"	3"	10-1/2" (14-1/4")	3/8"
3328	C	1/8"	1/4-28	9/16"	1-3/8"	8-1/2" (11-1/2")	5/16"
3329	C	3/16"	1/4-28	9/16"	1-3/8"	8-3/4" (11-3/4")	5/16"

* Longer shaft lengths available

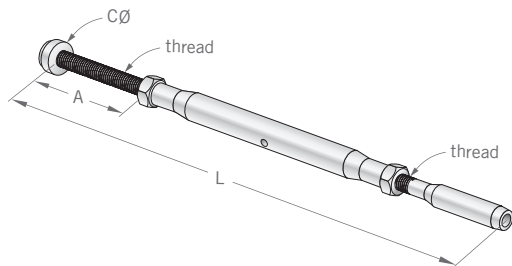

BALL END TURNBUCKLE

- Inserts through a drill hole or slot in end post and attaches with a screw-on ball
- Ball pivots to allow angled stair terminations without beveled washers
- Typically paired with a Fixed Ball End or another Ball End Turnbuckle

Part#	Swage	CableØ	Thread	DØ	A* close	L close (open)	DrillØ**
3340	M	1/8"	1/4-28	5/8"	1-1/4"	7-1/2" (10-1/2")	5/16"
3341	M	3/16"	1/4-28	5/8"	1-1/4"	8" (11")	5/16"
3342	M	1/4"	5/16-24	5/8"	2-7/8"	10-1/4" (14")	3/8"
3343	C	1/8"	1/4-28	5/8"	1-1/4"	8-1/4" (11-1/4")	5/16"
3344	C	3/16"	1/4-28	5/8"	1-1/4"	8-1/2" (11-1/2")	5/16"

* Longer shaft lengths available

** Ball can be slightly recessed into post by counter-boring with 9/16" drill

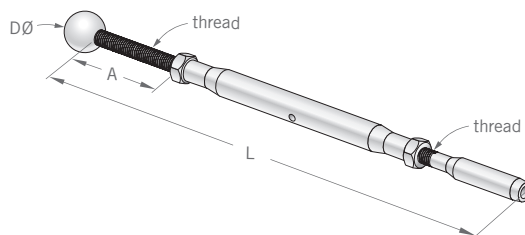

M Machine Swage

C CableCrimp™ Hand Swage

See pages 30 & 31 for accessory items and tools

1-800-888-2418

feeneyarchitectural
PRODUCTS

316-GRADE STAINLESS STEEL Tension Adjustment Fittings

THE SLEEKLINE SERIES TURNBUCKLES

have a swage sleeve hidden inside the body allowing a shorter turnbuckle design with clean lines and no exposed threads or swage ends. Sleekline Turnbuckles are best suited for attaching to the cable in the field using the CableCrimp™ style fittings and a CableCrimp™ Crimper tool (#3742).

SLEEKLINE JAW TURNBUCKLE

- Attaches to eyebolts, eyelets, or drilled tabs using a removable clevis pin
- 180 degree pivoting is ideal for angled stair terminations
- Typically paired with a Fixed Jaw End or another Sleekline Jaw Turnbuckle

Part#	Swage	CableØ	PinØ	TL	G	SØ	L close (open)	Pin DrillØ
3295	M	1/8"	1/4"	15/16"	5/16"	1/4"	6-3/8" (8")	5/16"
3296	M	3/16"						
3297	C	1/8"						
3299	C	3/16"						

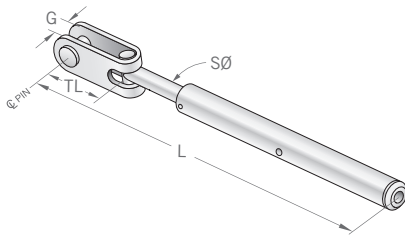

Note on charts: **DrillØ** is the recommended drill hole size for attaching the fittings to the end posts. Drill hole sizes for all other intermediate posts may differ. Please call to confirm correct drill sizes.

SLEEKLINE SURFACE MOUNT TURNBUCKLE

- Attaches to face of the post using lag screws or bolts (#3183 or #3322)
- 130 degree pivoting allows for angled stair terminations
- Typically paired with a Fixed Surface Mount or Sleekline Surface Mount Turnbuckle

Part#	Swage	CableØ	EØ	H	W	SØ	L close (open)
3309	M	1/8"	1/4"	1-5/16"	5/8"	1/4"	5-5/8" (7-1/4")
3310	M	3/16"					
3311	C	1/8"					
3312	C	3/16"					

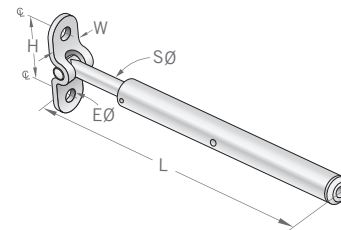

SLEEKLINE CAP END TURNBUCKLE

- Inserts through a drill hole in the end post and attaches with a screw-on end cap
- Use beveled washer (#3793) for angled stair terminations and flat washers (page 31) for added bearing surface on wood posts
- Typically paired with a Fixed Cap End or another Sleekline Cap End Turnbuckle

Part#	Swage	CableØ	CØ	A close	SØ	L close (open)	DrillØ
3300	M	1/8"	9/16"	3-1/2"	1/4"	8-1/4" (9-7/8")	5/16"
3302	M	3/16"					
3305	C	1/8"					
3282	C	3/16"					

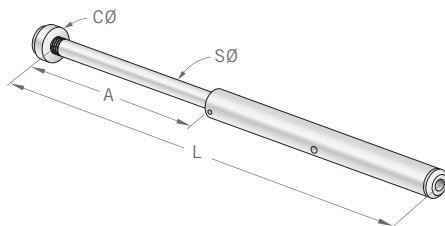

SLEEKLINE BALL END TURNBUCKLE

- Inserts through a drill hole or slot in the end post and attaches with a screw-on ball
- Ball pivots to allow angled stair terminations without beveled washers
- Typically paired with a Fixed Ball End or another Sleekline Ball End Turnbuckle

Part#	Swage	CableØ	DØ	A close	SØ	L close (open)	DrillØ*
3345	M	1/8"	5/8"	3-3/8"	1/4"	8-1/8" (9-3/4")	5/16"
3346	M	3/16"					
3350	C	1/8"					
3351	C	3/16"					

*Ball can be slightly recessed into post by counter-boring with 9/16" drill.

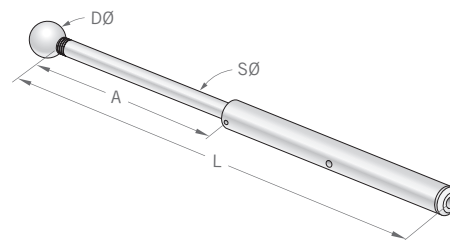

M Machine Swage
C CableCrimp™ Hand Swage
See pages 30 & 31 for accessory items and tools

316-GRADE STAINLESS STEEL Nuts, Bolts & Tools

HOW TO ORDER CABLERAIL™

- Carefully Review:** Read all of the product information provided in this catalog and on our website www.cablerail.com. If you have questions, please call our sales department for assistance, 1-800-888-2418.
- Select Cable:** Decide on the cable size and construction.
- Select Fittings:** Select the style and swage type (Machine or CableCrimp). Remember, each assembly must include at least one Tension Adjustment Fitting.
- Calculate Assembly Lengths:** See the installation steps and "measure point" chart on page 32.
- Determine Quantities:** Quantities depend on the railing design. Remember, space cables no more than 3 inches apart.
- Check Accessories:** Make sure you have all the necessary nuts, screws, caps, washers, crimpers, cutters, etc.
- Place the Order:** Please call, fax or e-mail us your final list for order processing. Orders ship via UPS.

FREE: 1-800-888-2418
 PH: 1-510-893-9473
 FAX: 1-510-893-9484
 SALES@FEENEYWIRE.COM
 WWW.CABLERAIL.COM

feeneyarchitectural PRODUCTS | 1-800-888-2418



NEW! SNUG-GRIP™ WASHER NUTS

- Option for securing Threaded Terminal fittings to posts
- It's a washer, retaining ring and lock nut wrapped into one fitting
- Cable tension is adjusted by spinning the nut, and special Snug-Grip™ threads help prevent loosening
- Special raised lip allows for easy attachment of Colored and Stainless End Caps

Part#	Thread	Part#	Thread
3370	1/4-20RH	3371	5/16-24RH



HEX NUTS

- Option for securing Threaded Terminal fittings to posts
- Tension is adjusted by spinning the nut
- Typically used in conjunction with Cap Nuts to provide a finished detail

Part#	Thread	Part#	Thread
3143	1/4-20RH	3244	5/16-24RH
3178	1/4-28RH	3242	5/16-24LH
3243	1/4-28LH		



NYLON INSERT LOCKNUTS

- Option for securing Threaded Terminal fittings to posts
- Tension is adjusted by spinning the nut, and an integrated nylon insert prevents the nut from loosening
- Typically paired with a Retaining Washer (#7070) and covered with a Colored End Cap

Part#	Thread	Part#	Thread
3121	1/4-20RH	3175	1/4-28RH



CAP NUTS

- Option for finishing and locking hex nuts on Threaded Terminal fittings

Part#	Thread	Part#	Thread
3144	1/4-20RH	3188	5/16-24RH
3179	1/4-28RH		



HEX HEAD LAG SCREWS (18-8 STAINLESS)

- For attaching Surface Mount Fittings to wood posts

Part#	Size & Length
3183	1/4" x 2"



HEX HEAD BOLTS

- For attaching Surface Mount Fittings to metal posts
- Drill and tap metal for 1/4-20RH threads

Part#	Thread & Length
3322	1/4-20RH x 3/4"



PROTECTOR SLEEVES

- (Wood posts only) For protecting corner and stair transition posts from cable abrasion
- Use with 1/8" and 3/16" diameter cable
- Fits 1/4" diameter drill holes

Part#	Size & Length	Flange
3210	1/4" x 7/8"	1/2"



SHOULDER EYEBOLT

- Option for attaching Jaw Fittings to posts
- Includes washer and hex nut for securing to post

Part#	Size & Length
5057	5/16-18RH x 4"



RETAINING WASHERS

- For attaching Colored End Caps over the Hex Nuts and Nylon Insert Lock Nuts
- Raised lip allows End Caps to easily snap and lock-on

Part#	Size x OD
7070	1/4" x 5/8"



FLAT WASHERS (STAINLESS)

- For providing additional bearing surface to end fittings on wood posts

Part#	Size x OD	Part#	Size x OD
3180	1/4" x 11/16"	3378	3/8" x 1"
3181	1/4" x 1"	3177	9/16" x 1"
3231	5/16" x 3/4"		



FLAT WASHERS (NYLON)

- For protecting metal posts from nut abrasion and electrolysis

Part#	Size x OD	Part#	Size x OD
3375	1/4" x 3/4"	3376	3/8" x 3/4"
3377	5/16" x 3/4"	3379	9/16" x 3/4"



BEVELED WASHERS

- For providing a flat bearing surface when attaching fittings at angled stair terminations

Part#	Size x OD	Part#	Size x OD
3791	1/4" x 1/2"	3792	3/8" x 3/4"
3799	9/32" x 3/4"	3798	9/16" x 3/4"
3793	5/16" x 5/8"		

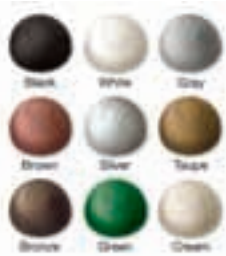

COLORED END CAPS (POLYETHYLENE)

- Option for covering and finishing the exposed ends of Threaded Terminal nuts and QuickConnect-SS™ fittings
- Fits Washer Nuts, Retaining Washers and QuickConnect-SS™ fittings
- Size 3/4"O.D. x 7/16"H

Part#	Color	Part#	Color
7071	Black	7075	Silver
7072	White	7076	Taupe
7073	Brown	7077	Bronze
7074	Gray	7078	Green
		7079	Cream



STAINLESS END CAPS

- Decorative option for covering and finishing the exposed ends of QuickConnect-SS™ and Snug-Grip™ Washer Nuts
- Will not fit onto Retaining Washers
- Size 3/4"O.D. x 3/8"H

Part#	Style	Part#	Style
3372	Dome	3374	Chamfer
3373	Crown		

DRILL BITS

- For drilling cable and fitting attachment holes in posts

Part#	Size x L	Part#	Size x L
3201	1/4" x 6"	3218	7/16" x 7-1/2"
3203	5/16" x 6-1/2"	3225	9/16" x 6"
3217	3/8" x 6-1/2"	*3204	9/16" x 6"(spade)

*Note: #3204 spade bit for wood only.

BI-METAL SAW BLADES

- For trimming excess threads on Threaded Terminal fittings

Part#	Description
3199	12" Hacksaw blade
5065	6" Reciprocating Saw blade

CABLE LACING NEEDLES

- For quickly lacing cable ends through posts without snagging
- Needle length 4-1/2"

Part#	Cable Size	Part#	Cable Size
3221	1/8"	3223	1/4"
3222	3/16"		

ABRASIVE DISKS

- For trimming and touching-up exposed cable and threads
- Fits 4-1/2" electric grinders with 7/8" arbor holes

Part#	Description	Part#	Description
3219	Cut-Off Disk	3220	Grinding Disk

CABLECRIMP™ CRIMPER

- For attaching 1/8" and 3/16" CableCrimp™ style hand crimp fittings in the field

Part#	Description
3742	Double-cavity x 20" long

CABLE CUTTERS

- For shearing stainless steel cables

Part#	Cable Size	Length
2972-pkg	Up to 1/8"	7-1/2"
2971	Up to 1/4"	13"

LOCTITE® 290 THREADLOCKER

- For keeping nuts, bolts and turnbuckle bodies from spinning loose after installation
- Special penetrating formula can be applied after parts are attached
- 10ml bottle locks approximately 200 parts

Part#	Description
29021-pkg	10ml squeeze bottle.

ENVIRO-MAGIC® CLEANER

- For cleaning and protecting cables and hardware
- Non-toxic, biodegradable

Part#	Description
5063	16 oz. spray bottle

Custom Cable Assemblies Are Easy To Install.

Railing infill is the most common use of custom cable assemblies, and the installation steps outlined below are directed to that usage. However, the basic concepts would apply to both fence and trellis projects as well. For more comprehensive installation information, please visit our website www.cablerail.com, or call our toll-free line at 1-800-888-2418 for assistance.

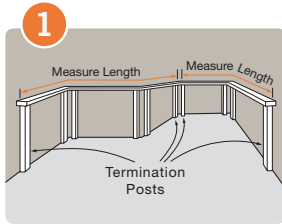

1 Select your cable and fittings, and construct your railing frame accordingly. Determine which posts or walls will be used for terminating the cable assemblies. See railing frame recommendations on pages 34 & 35.

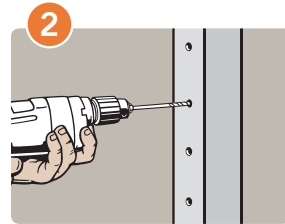

2 Mark and drill holes in all posts. Hole sizes will vary depending on the size and style of cable fittings used.

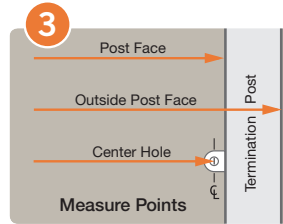

3 Determine the lengths of your cable assemblies by measuring the distance between the "measure points" on the termination posts. The "measure point" depends on the style of fittings used (see Fitting Measure Point chart below).

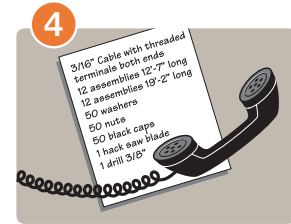

4 Call to ask questions and to order the cable assemblies and accessories: toll-free 1-800-888-2418 or 1-510-893-9473.



5 Lace the cable assemblies through your intermediate posts and attach the end fittings to the termination posts. See drawings on page 33 for details on angled stair terminations.

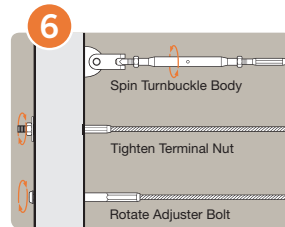

6 Tighten the cables using the Tension Adjustment Fittings. Depending on the fittings used, trim any excess material and apply caps to finish the ends.

Measure Point for Each Type of Fitting

Fitting Type	Post Face	Outside Post Face	Center Hole
All Surface Mount style turnbuckles	X		
Fixed Surface Mounts	X		
Fixed Lock Toggles	X		
Threaded Terminals		X	
Internal Thread Adjusters		X	
All Cap End style turnbuckles		X	
All Ball End style turnbuckles		X	
Fixed Cap Ends		X	
Fixed Ball Ends		X	
QuickConnect-SS™		X	
Fixed Button Heads		X	
All Jaw style turnbuckles			X
Fixed Jaw Ends			X

CONSTRUCTION CHECKLIST

- Space cables no more than 3 inches apart
- Space posts/verticals no more than 3 feet apart
- Observe minimum end/corner post sizes shown on page 34
- Securely fasten all posts and cap rails
- Carefully plan all termination and corner posts for proper clearance, positioning, and maximum cable run lengths
- To ensure proper tensioning, straight runs of cable (no turns, dips or rises) should include a Tension Adjustment Fitting at least every 50 feet
- Runs with bends or corners should have a Tension Adjustment Fitting at least every 40 feet or after every second corner bend (whichever distance is shorter)

IMPORTANT NOTES

- Since building codes vary by state, county and city, our recommendations may not comply with code requirements in all areas. Always consult with your local building department before starting your project.
- CableRail™ cable assemblies and fittings are designed for use on railings, fences and trellises only. They should never be used for lifting, hanging or high load applications.



Builder: Ellerbe Becket, Minneapolis MN

Typical Angled Terminations

Note: These attachment details also apply to the corresponding turnbuckles.

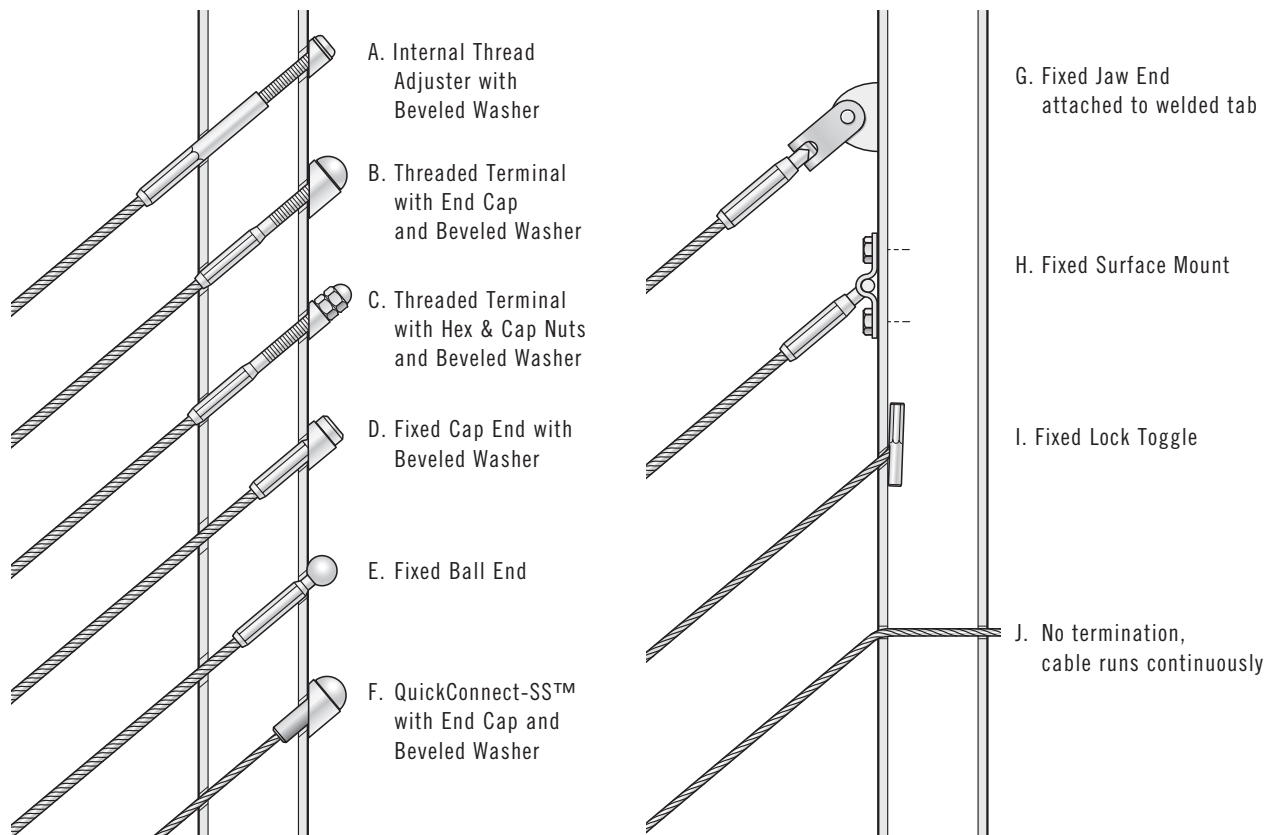

Frames need to support the tension of properly installed cables.

They need to be designed and built strongly enough to support a load of at least 300 lbs for each cable. Frames can also be designed to use cables more efficiently, thereby reducing the total quantity of cable assemblies needed and the overall cost. Below are some basic guidelines to help you prepare railing frames for cable infill. We also encourage you to carefully review all of the cable and fitting detail pages and installation pages, and if you have any questions, please call us at 1-800-888-2418 for assistance.

Minimum sizes for all corner and end posts

All other posts should be sized as required for cap rail support strength or for code

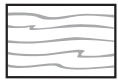

4X6 WOOD
3-1/2" wide, 5-1/2" thick



FLAT BAR
2" wide, 1" thick



ANGLE IRON
2" wide, 1/2" thick



EXTRA STRONG PIPE
1-1/2" I.D., 1-7/8" O.D.



SQUARE TUBE
2" wide, 1/4" wall

The Basic Frame Design

Spacing From Walls

Unless using Surface Mount or Jaw type cable fittings, always set end posts 3 to 4 inches away from the wall face to allow access for attaching cable end fittings through the post.

Cap Rail

Always include a strong, rigid cap rail that is securely fastened to all posts. Cap size is based on load strength needs and local code requirements. Set railing height per local code.

Cable Spacing

Maximum 3 inches apart.

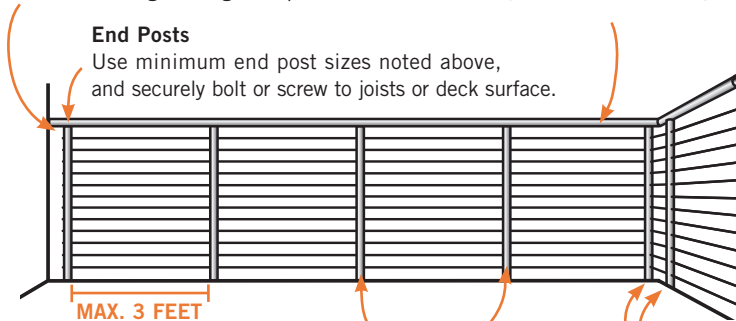

End Posts

Use minimum end post sizes noted above, and securely bolt or screw to joists or deck surface.

Wood Blocking (WOOD FRAMES ONLY)

Underneath the cap rail, attach minimum 1" x 4" size wood blocking between posts to provide additional lateral reinforcement so that they will not pull out of plumb when the cables are tensioned.

Maximum Post Spacing

Space all posts and vertical spacers (see adjacent page) a maximum of 3 feet apart to minimize any deflection that may occur if the cables are ever forced apart.

Intermediate Posts

Size all intermediate posts as required for cap rail support strength or for code.

Double Corner Posts

If possible, use double corner posts to allow the cable to run continuously through the corners without terminating. Securely bolt or screw posts to joists or deck surface and use minimum corner post sizes noted above.



Builder: The Steel Guys, San Leandro CA

And Some Other Options

Vertical Spacers (OPTIONAL)

Slender spacers may be used instead of larger intermediate posts to achieve a more open railing design. These are non-structural members and are only intended to maintain cable spacing and minimize deflection. Examples are 2" x 2" wood strips, 1" metal tubing or 1/4" flat bar. Attach to the cap rail and either the foot rail, deck surface or joists.

Cable Spacing

Maximum 3 inches apart.

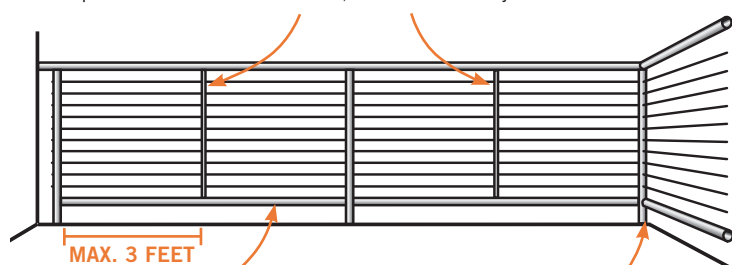

Foot Rails (OPTIONAL)

Foot rails should be spaced no more than 4 inches above the deck surface, or as required by local code, and should be sized as needed for support strength and design appearance.

Single Corner Post (OPTIONAL)

In most cases with single corner posts, cables must be terminated. Exceptions are angle iron posts or tubular metal posts (when using hand crimp fittings). When terminating on a single corner post, be sure to offset the drill holes at least 1/2" to allow internal clearance for the cable fittings. Use minimum end post sizes noted on page 34, and securely bolt or screw to joists or deck surface.

A FEW WORDS ABOUT STAINLESS STEEL

The protective chromium oxide film on the surface of stainless steel gives it superior corrosion resistance. Properly maintained stainless steel provides excellent luster, strength and durability. In most applications, stainless steel will not rust or stain even after years of service, but it is NOT rust or stain proof. When stainless comes in contact with chloride salts, sulfides or other rusting metals, it can discolor or even rust and corrode. With proper care and maintenance, however, stainless steel can remain beautiful and functional for years to come, even when it is exposed to marine environments, polluted surroundings, salted highways, or other corrosive elements. For complete care and maintenance instructions, please visit our website www.cablerail.com.

10 YEAR LIMITED WARRANTY: Feeney Inc (Feeney) warrants that all CableRail™ stainless steel cable and connectors shall be free from defects in material and workmanship under normal use, conditions, installation and maintenance in accordance with product specifications for ten (10) years from date of purchase. The complete text of this warranty is available on our website www.cablerail.com.

DESIGN·RAIL™ Aluminum Railing Systems

Searching For a Complete Railing System? Look No Further.

DesignRail™ Aluminum Railing Frame Systems combine the durability of aluminum with innovative design details to ensure lasting beauty, structural integrity, easy installation and affordability while drastically reducing long term maintenance expenses. All rails and stanchions are made from high-strength 6000-series aluminum extrusions that can be quickly and easily cut and assembled on site, using pre-engineered components that snap and screw together. DesignRail™ Aluminum Railing Systems are easily adaptable to any project: interior or exterior, commercial or residential. Simply choose the style options that are best for your project to custom design your railing.

- Available in a variety of cap rail styles as well as cable, glass and picket infill options
- Durable powder-coated finishes offer superior color retention, impact resistance and weather protection
- Available in an assortment of colors that meet rigorous AAMA-2604 coating specifications
- Low maintenance with long use cycle: no rusting, cracking, peeling or repainting
- Easy field assembly with components that snap and screw together: no welding, grinding or special finishing
- Lightweight materials reduce shipping costs, save fuel, and are easier to handle on the job
- Accessory items include ADA compliant grab rails, custom gates and low-voltage LED lights
- Detail drawings and 3-part specifications available at www.designrail.com
- Toll-free design assistance and technical support line, 1-800-888-2418

1-800-888-2418

feeneyarchitectural
P R O D U C T S



DesignRail

Posts

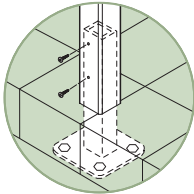
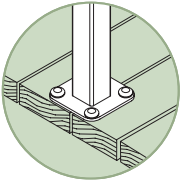
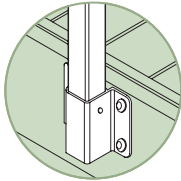
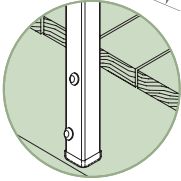
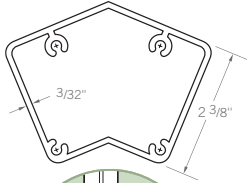
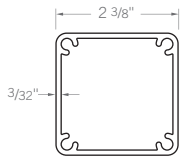

Posts are made from heavy-duty 2-3/8" square tube extrusions with a 3/32" wall thickness. Posts for horizontal railings come pre-cut for 36", 38" and 42" railing heights. Stair or custom posts must be cut to height in the field and extrusions can be ordered in 10-ft or 20-ft lengths for that purpose. Posts also come pre-drilled for cables when using horizontal cable infill (except stair posts which must be field-drilled). All square posts can be fascia, surface, fascia bracket, or stanchion mounted.

We also offer a 45° corner post that allows single post construction at 45° corners. These extrusions come pre-cut and pre-drilled (except when used on stairs) and can be surface or fascia mounted.

FASCIA MOUNT

- For side mounting to fascia boards, joists or walls
- Posts come with pre-drilled bolt holes

FASCIA BRACKET MOUNT

- For side mounting to fascia or rim joists when decking or nosing trim extends beyond the edge of the fascia board
- Posts are attached using metal brackets that are available with either a 3/4" or 1-1/4" standoff
- Railing must have a bottom foot rail when using this mounting method

SURFACE MOUNT

- For top mounting to deck, patio or stair tread surfaces
- 5-inch square base plates come pre-attached

STANCHION MOUNT

- For mounting on stone or tile covered concrete slabs or on roof decks where penetration of waterproof roofing membranes must be minimized
- Short stanchions are attached to the structural members prior to pouring the slab or laying the roof membrane
- Railing posts are then sleeved over the protruding stanchion ends and secured with screws

1-800-888-2418

feeneyarchitectural
P R O D U C T S

Cap Rails

Cap rails come in 5 styles and are sold in 10-ft and 20-ft lengths that can be trimmed to size in the field. Series 100 Graspable Cap Rails are used exclusively on stairs to provide a graspable top rail, and they are attached to the faces of the stair posts using Rail Connecting Blocks (RCBs). Series 200, 300, 350 and 400 Cap Rails rest on the tops of the posts and are secured with stainless steel screws. Applied Continuous Grab Rails with extensions and returns (see page 44) are available as an accessory item to meet ADA and code stair grab rail requirements.

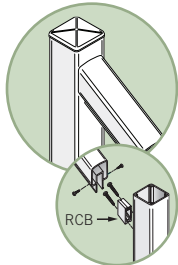

SERIES 100 CAPS FOR STAIRS

- 2" wide graspable cap rail for stairs
- Meets residential code requirements for stair grab rail sizing
- Requires an Applied Grab Rail (page 44) when used on stairs in commercial settings

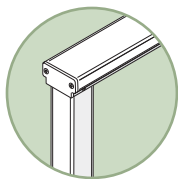
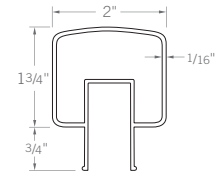

SERIES 200 CAPS

- 3-1/2" wide rectangular cap rail
- The flat surface is a convenient perch for your favorite beverage as you relax and gaze at the view
- Requires an Applied Grab Rail when used on stairs

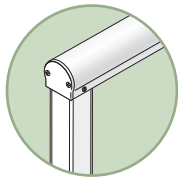
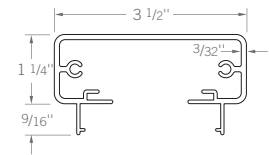

SERIES 300 CAPS

- 1-1/2" radius cap rail
- The smooth rounded shape offers a more contemporary accent to those less traditional architectural designs
- Requires an Applied Grab Rail when used on stairs

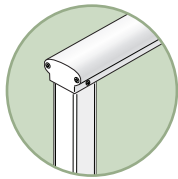
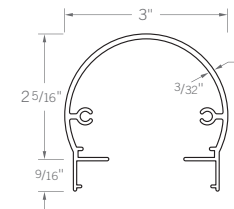

SERIES 350 CAPS

- 3-1/2" wide elliptical cap rail
- The sleek, stylish design offers another option for those who prefer a less angular cap rail appearance
- Requires an Applied Grab Rail when used on stairs

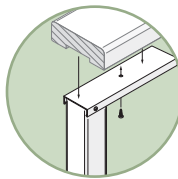
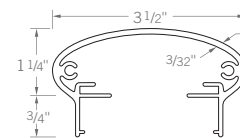

SERIES 400 CAPS

- Low-profile cap for adding your own wood or composite top rails (must be used with top rail to achieve necessary frame strength—wood and composite top rails not included)
- Requires an Applied Grab Rail when used on stairs

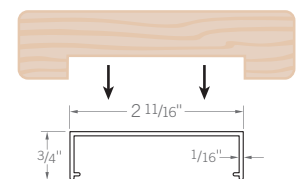

DesignRail

Frame Colors

- Durable powder-coated finishes are available in 8 standard colors and over 200 custom colors
- Finishes meet rigorous AAMA-2604 coating specifications for superior color retention, impact resistance and weather protection



The standard color samples shown above represent approximate color only.

Infill

The basic infill options are illustrated below. However, Feeney can also assist with custom infill options such as textured, etched or decaled glass panels, special picket designs, or even wood strips or panels for solid barriers or fences.

All infill options require a horizontal Foot Rail and a Cap Infill Channel (Foot Rails are optional for 36" and 38" high frames using horizontal cable infill). These support the railing infill and help reinforce the frame structure. Foot Rails connect to the posts using Rail Connecting Blocks (RCBs), and Cap Infill Channels snap into the underside of the Cap Rails. Each infill type has a specific corresponding Foot Rail and Cap Infill Channel design. Foot Rails and Cap Infill Channels are available in 10-ft and 20-ft lengths that can be cut to size in the field.

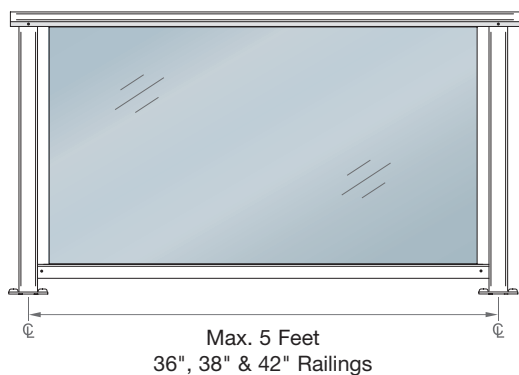
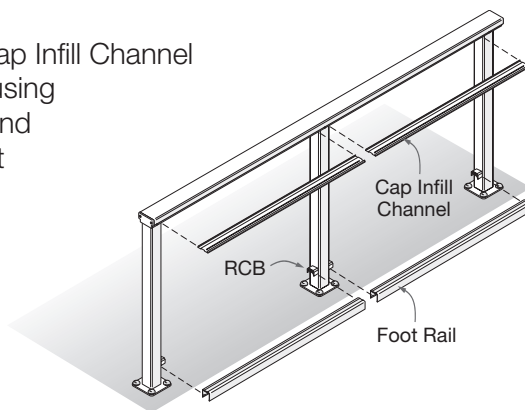

TEMPERED GLASS

- Clear or custom tinted panels that are easily inserted into vinyl lined slots in the Cap Infill Channel and Foot Rail
- No special mounting hardware needed
- Glass panels are shipped cut to size after the frames are constructed and final opening measurements are submitted

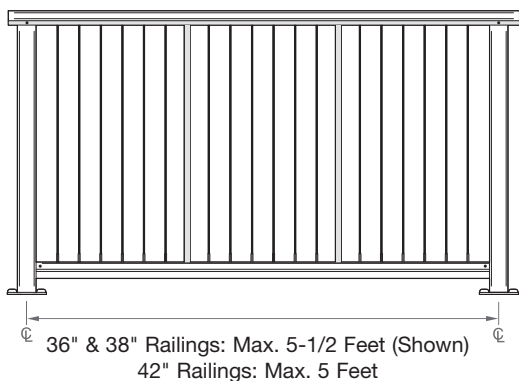

VERTICAL CABLES

- 1/8" diameter 316-grade stainless steel cables come prefabricated to size with all of the attachment fittings, ready to install
- Two vertical intermediate pickets are spaced mid-span to maximize frame rigidity
- Vertical cable infill cannot be used with Series 400 cap rails

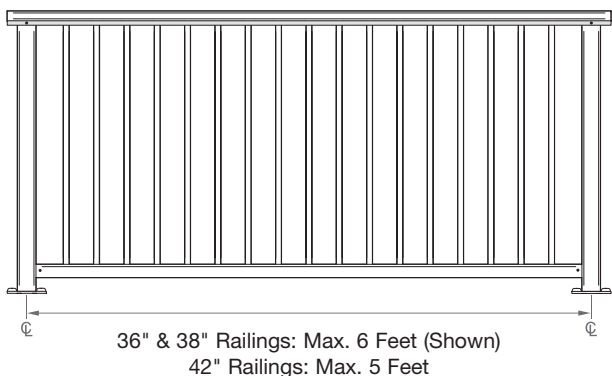

VERTICAL PICKETS

- 3/4" square aluminum Pickets that come cut to size, ready to install
- Pickets are powder coated to match the frame color

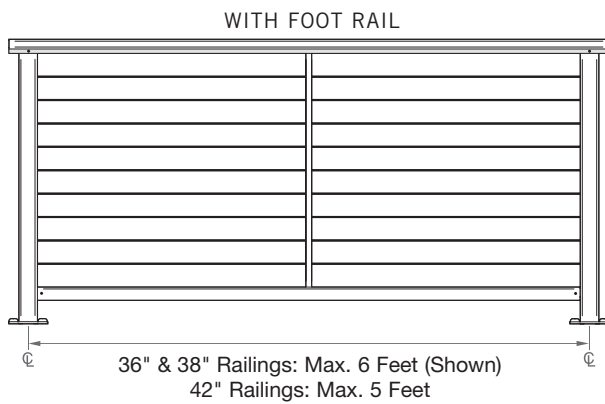
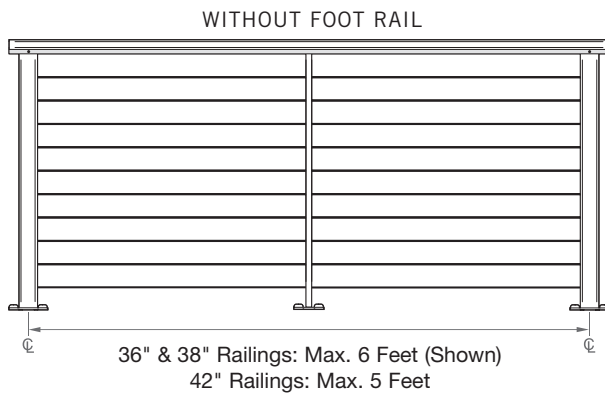

HORIZONTAL CABLES

- 1/8" diameter 316-grade stainless steel CableRail™ cable assemblies (see page 12) include all of the attachment fittings and come prefabricated in standard lengths that can be trimmed to exact dimensions in the field
- A vertical intermediate picket is used mid-span to minimize cable deflection
- All posts and pickets (except those used on stairs) come pre-drilled, ready for cable installation

Horizontal Foot Rails are required for 42" high frames and may be used as an option on 36" and 38" frames.





Project: Heather's Home, Ferrier Custom Homes.

Tools



MILL BASTARD FILE

- For smoothing edges and removing burrs on aluminum parts after cutting

Part#	Type	Length
5032	Single cut	8"



CARBIDE SAW BLADES

- For cutting aluminum posts, caps and channels
- High-grade, fine-tooth blades fit standard chop saws

Part#	O.D.	Hole	Teeth/Inch
5030	10"	5/8"	80
5031	12"	1"	96



CABLE CUTTER

- For shearing stainless steel cables cleanly and easily

Part#	Cable Size	Length
2972-pkg	Up to 1/8"	7-1/2"



ABRASIVE DISKS

- For trimming and touching-up exposed cable and threads
- Fits 4-1/2" electric grinders with 7/8" arbor holes

Part#	Type
3219	Cut-Off Disk
3220	Grinding Disk



CABLE LACING NEEDLE

- For quickly lacing cable ends through posts without snagging

Part#	Cable Size	Length
3221	1/8"	4-1/2"



ENVIRO-MAGIC® CLEANER

- For cleaning and protecting stainless steel cables and hardware
- Non-toxic, biodegradable

Part#	Description
5063	16 oz. spray bottle

Construct your railing frame in 5 simple steps.

DesignRail™ Aluminum Railing Systems are designed to quickly screw and snap together on site with only a few basic tools. Detailed installation instructions are included with each order and are also available on our website www.designrail.com.

1 Install Posts

Install the posts starting with the end and corner posts, continuing on to the intermediate posts.

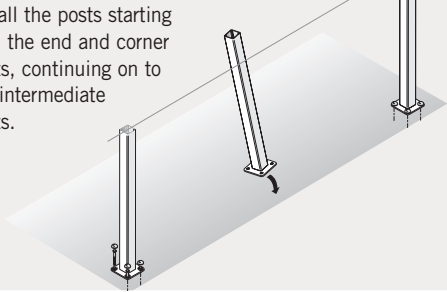

2 Attach Cap Rails

Measure and cut the Cap Rails and attach to posts using screws.

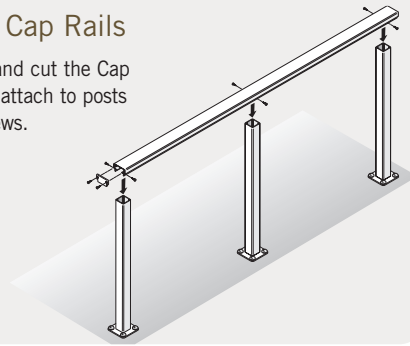

3 Attach RCBs

If using Foot Rails, screw the Rail Connecting Blocks (RCBs) to the posts for attaching the Foot Rails.

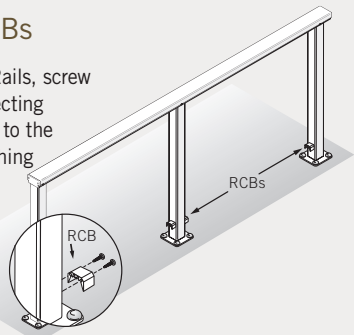

4 Prepare Infill Supports

Measure and cut Cap Infill Channels and Foot Rails for each panel section.

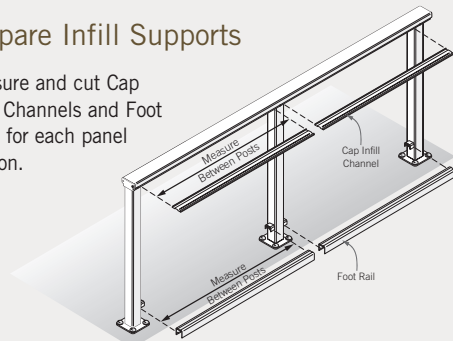

5a Picket Infill Option

Screw pickets to the Cap Infill Channel and Foot Rail. Then lift the complete panel into position on the railing frame and screw in place.

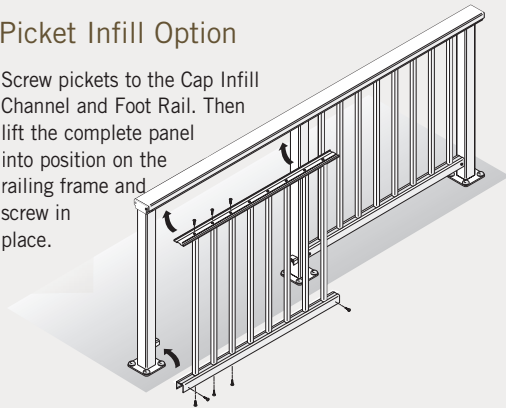

5b Glass Infill Option

Attach Cap Infill Channel and Foot Rail to railing frame and insert vinyl liners. Lift the pre-cut panels into the Cap Infill Channel, then lower into final position in Rail slot.

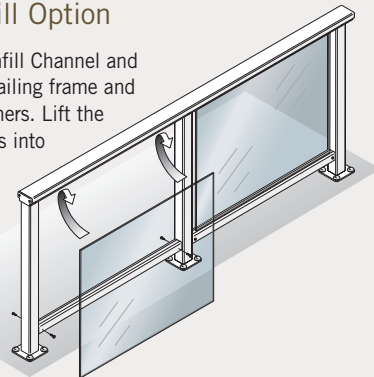

5c Horizontal Cable Infill Option

Screw intermediate pickets to Cap Infill Channel and Foot Rail (if using Foot Rail), then lift into position on frame and screw in place. Lace cables through pre-drilled holes in posts and pickets, then tighten.

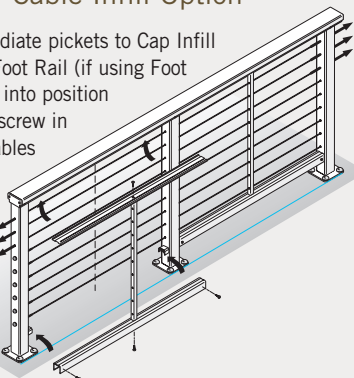

5d Vertical Cable Infill Option

Screw intermediate pickets to Cap Infill Channel and Foot Rail and loosely attach cables. Lift entire panel into position on railing frame and screw in place. Tighten nuts at bottom for final cable tension.

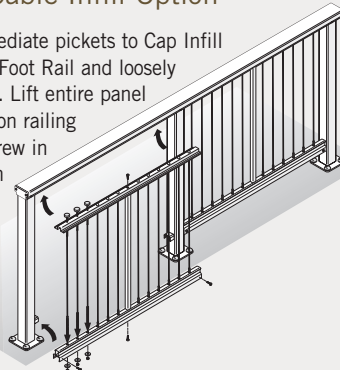

Additional Items

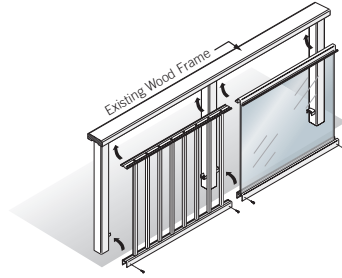

CUSTOM PANELS

- Prefabricated aluminum picket or glass infill panels to fit your existing wood railing frames
- Custom fabricated to fit your individual railing design
- Easy to install and low maintenance
- Panels are shipped ready to install

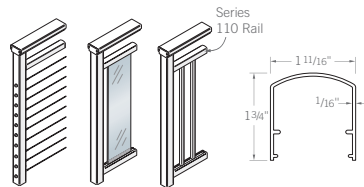

INTERMEDIATE HORIZONTAL RAILS (SERIES 110)

- Used with picket, glass and horizontal infill for creating railing designs with partial height infill
- Sold in 10-ft and 20-ft lengths that can be trimmed to size in the field
- Attaches to the post faces using Rail Connecting Blocks (RCBs)

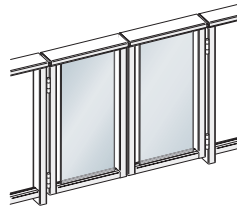

GATES

- Custom fabricated to size
- Available for all railing styles and infill types

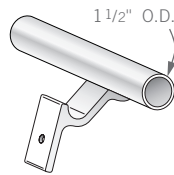
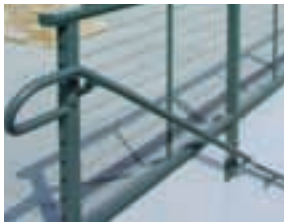

APPLIED CONTINUOUS GRAB RAILS

- 1-1/2" diameter, aluminum grab rails to meet stair railing code requirements
- ADA compliant extensions and returns
- Custom bent and fabricated, ready for installation

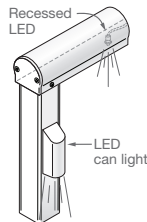

LOW VOLTAGE LED LIGHTS

- Direct 12 volt LED recessed and can-style lights
- Installation must be done by a licensed electrician

1-800-888-2418

feeneyarchitectural
P R O D U C T S





DesignRail

1-800-888-2418

feeneyarchitectural
P R O D U C T S



HOW TO ORDER DESIGNRAIL™

- 1) **Carefully Review:** Read all of the product information provided in this catalog and on our website www.designrail.com. If you have questions, please call our sales department for assistance, *1-800-888-2418*.
- 2) **Determine Frame Height:** 36", 38" or 42".
- 3) **Decide Post Mountings:** Fascia, surface, fascia bracket or stanchion mount.
- 4) **Select Cap Rail:** Series 200, 300, 350, 400 or Series 100 for stairs.
- 5) **Choose Infill:** Aluminum picket, glass, horizontal cable or vertical cable.
- 6) **Pick Frame Color:** Choose from the 8 standard colors or call for custom colors.
- 7) **Review Other Items:** Will you need stair grab rails, low voltage lights or gates?
- 8) **Confirm Details & Prices:** All railing projects are unique. Call us at *1-800-888-2418*, and our staff will assist you in confirming a list of the parts needed for your project and provide you with a price quote.
- 9) **Place Your Order:** Please call, fax or e-mail us your final list for order processing. Standard orders ship via common truck carrier, freight collect.

FREE: 1-800-888-2418
PH: 1-510-893-9473
FAX: 1-510-893-9484
SALES@FEENEYWIRE.COM
WWW.DESIGNRAIL.COM

Note On Packaging

All DesignRail™ aluminum frames and components are carefully packaged to ensure that products arrive damage-free. Cap Rails, Foot Rails and Cap Infill Channels are shipped in special 10-ft and 20-ft boxes, and all posts and hardware items are boxed, wrapped and shipped on standard pallets.

IMPORTANT NOTE

Building codes vary by state, county and city, so be sure to consult with your local building department before starting your project.

10 YEAR LIMITED WARRANTY

Feeney Inc (Feeney) warrants that all DesignRail™ Aluminum Component Railing Systems adhere to AAMA 2604 coating specification guidelines and will not crack, flake, blister or peel under normal use, conditions, installation and maintenance in accordance with product specifications for ten (10) years from date of purchase. In addition, Feeney warrants that the stainless steel cable and connectors shall be free from defects in material and workmanship under normal use, conditions, installation and maintenance in accordance with product specifications for ten (10) years from date of purchase. The complete text of this warranty is available on our websites www.designrail.com and www.cablerail.com.



CABLE·TRELLIS™

Stylish, Easy-to-Install Trellises For Residential and Commercial Settings.

Drawing from our vast experience with aluminum frames and stainless steel cables, rods and fittings, we have developed two simple and attractive vertical trellises for residential and commercial settings: the wall-mounted Somerset® Trellis and freestanding Greenway® Trellis.

CableTrellis™ trellises are sold in complete, easy-to-use kits with powder-coated aluminum support frames and sleek stainless steel cable and rod vine grids. Utilitarian, decorative and artistic, these trellises are perfect for displaying light- to medium-weight foliage and offer simple, elegant design details with exceptional versatility and easy installation. Use CableTrellis™ to minimize UV exposure on walls, control ambient heat gain, frame a lovely view, direct foot traffic or create a cool, relaxing retreat or entertaining area.

- Complete, easy-to-install kits available in an assortment of sizes and mounting options
- Aluminum support frames and brackets with durable, powder-coated finishes
- 316-grade stainless steel cables & rods for lasting beauty and weather-tough strength
- Fully adjustable rods with special Cross-Clamp connectors
- Variety of uses: extending gardens vertically, vegetable supports, privacy panels, space dividers, sun shades, decorative backdrops, and more
- Multiple kits can be combined to create the landscape design you desire
- Detail drawings and 3-part specifications available at www.cabletrellis.com
- Toll-free information and assistance line, 1-800-888-2418

1-800-888-2418

feeneyarchitectural
P R O D U C T S



Cable Trellis

Somerset® Wall Mount Trellis

The Somerset® Trellis is designed for mounting on vertical surfaces. It is an all-inclusive trellis kit, available in seven standard height packages (from 4 ft to 10 ft in 1-ft increments) with cables that can be field trimmed to your exact height requirements. It consists of powder-coated aluminum angle brackets top and bottom that screw or bolt to the wall face. Four 1/8" diameter stainless steel cable assemblies are strung vertically between the brackets and secured with special adjustable QuickConnect-SS™ and Threaded Terminal cable fittings. The 1/8" diameter stainless steel rods are then attached to the cables horizontally using special Cross-Clamps with locking setscrews.



QuickConnect-SS™ fittings with special one-way jaws automatically grab and lock on to the cable without any tools. Simply slide it on, pull the cable tight, trim the excess and finish with an end cap.



Cross-Clamps securely hold the rods in position using a locking setscrew. Decorative end caps provide a final finished detail. Cross-Clamps are available in hard-anodized aluminum or stainless steel.



Threaded Terminal fittings come pre-attached to one end of each cable. Spin on our unique Snug-Grip™ Washer Nut to adjust cable tension; the special Snug-Grip™ threads help prevent the nut from loosening. Finish with an end cap.

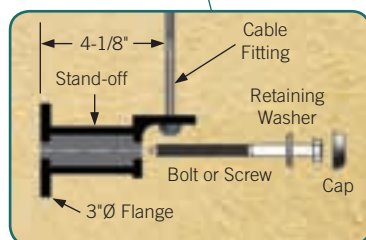

Built-in tubular standoffs provide optimal clearance from the wall face. Mounting bolts (sold separately, page 55) insert through the standoffs and into the wall. Retaining washers with caps cover the bolt heads.

1-800-888-2418

feeneyarchitectural
PRODUCTS

The rods can be positioned anywhere along the cables, but the spacing that we show and use in our standard package configurations is at 1 foot increments. Additional rods and clamps can be purchased as accessory items (see page 55). Multiple trellis kits can be mounted adjacent to one another to make wider wall trellises.

Trellis Kits With Hard-Anodized Cross-Clamps

Part #	Height	Rod Qty
T8604-1B	4'	3
T8605-1B	5'	4
T8606-1B	6'	5
T8607-1B	7'	6
T8608-1B	8'	7
T8609-1B	9'	8
T8610-1B	10'	9

Trellis Kits With Stainless Steel Cross-Clamps

Part #	Height	Rod Qty
T8604-1S	4'	3
T8605-1S	5'	4
T8606-1S	6'	5
T8607-1S	7'	6
T8608-1S	8'	7
T8609-1S	9'	8
T8610-1S	10'	9

EACH SOMERSET® TRELLIS KIT INCLUDES THE FOLLOWING

- ❑ 2 qty 40" long aluminum angle brackets with powder-coated finish
- ❑ 4 qty 1/8" diameter stainless steel cable assemblies with adjustable attachment fittings and plastic end caps
- ❑ 3 to 9 qty (depending on trellis height) 1/8" diameter x 38-1/4" long stainless steel rods
- ❑ 4 qty Cross-Clamps per rod with plastic caps (choose either hard-anodized aluminum or stainless steel Cross-Clamps)
- ❑ 4 qty retaining washers and large plastic caps to cover bracket attachment bolt/ screw heads (bolts and screws sold separately)
- ❑ 1 qty 3/16" hex key wrench (for Cross-Clamp setscrews)
- ❑ Installation instructions



Greenway® Freestanding Trellis

The Greenway® Trellis is a freestanding trellis kit made from 1-1/2" diameter powder-coated aluminum tubing. The pre-cut tubing sections easily sleeve together and are secured with locking screws. The legs can either be set in compacted gravel or concrete footings, or they can be trimmed and fitted with optional surface mount base plates. Four prefabricated 1/8" diameter stainless steel cables with adjustable threaded end fittings are strung vertically on the frame, and they support four 1/8" diameter stainless steel rods that are attached horizontally using Cross-Clamps with locking setscrews.

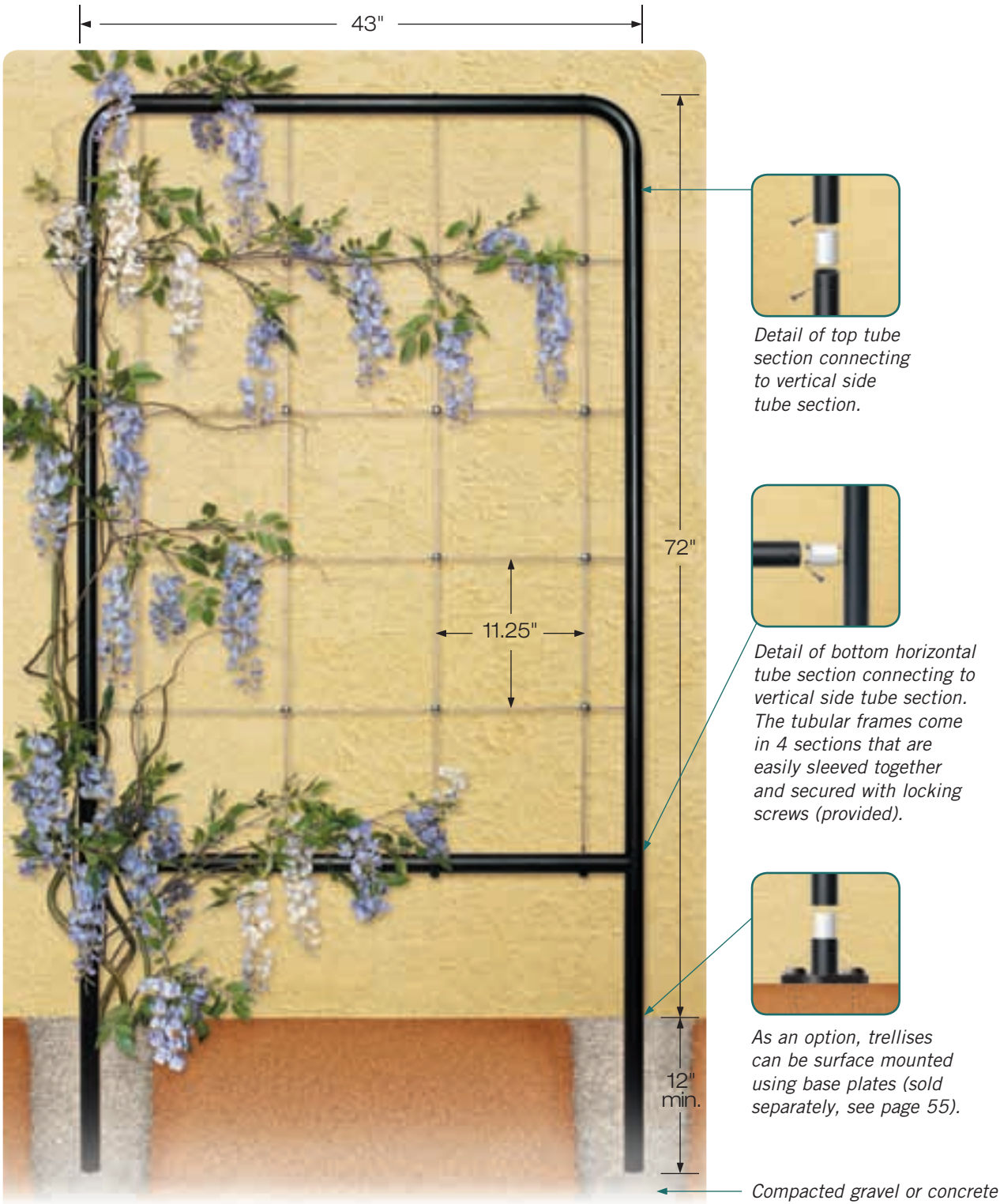

1-800-888-2418

feeneyarchitectural
PRODUCTS



Detail of top tube section connecting to vertical side tube section.



Detail of bottom horizontal tube section connecting to vertical side tube section. The tubular frames come in 4 sections that are easily sleeved together and secured with locking screws (provided).



As an option, trellises can be surface mounted using base plates (sold separately, see page 55).

Compacted gravel or concrete

Trellis shown with stainless Cross-Clamps and optional stainless caps



CABLE·TRELLIS™

The rods may be positioned anywhere along the cables, but the spacing that we show and recommend is 11-1/4 inch centers. Additional rods and clamps can be purchased as accessory items (see page 55). Multiple trellis kits can be combined in a variety of ways to create any effect you desire.

Trellis Kit With Hard-Anodized Cross-Clamps

Part #	Height	Rod Qty
T8506-1B	6'	4

Trellis Kit With Stainless Steel Cross-Clamps

Part #	Height	Rod Qty
T8506-1S	6'	4

EACH GREENWAY® TRELLIS KIT INCLUDES THE FOLLOWING

- 1 qty 1-1/2" diameter tubular aluminum frame with powder-coated finish. Frame comes in 4 sections that slip together with splice sleeves and locking screws (included). Installed dimensions are 72" high x 43" wide
- 4 qty 1/8" diameter stainless steel cable assemblies (prefabricated to exact length) with attachment fittings and plastic end caps
- 4 qty 1/8" diameter x 38-1/4" long stainless steel rods
- 16 qty Cross-Clamps with plastic caps (choose either hard-anodized aluminum or stainless steel Cross-Clamps)
- 1 qty 3/16" hex key wrench (for Cross-Clamp setscrew)
- 1 qty square-drive bit (for frame locking screws)
- Installation instructions



CableTrellis

Installing Your Somerset® Trellis.

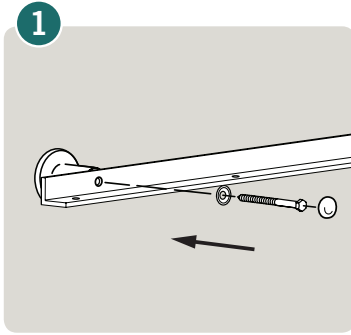

Securely fasten both the top and bottom support brackets to the wall with screws or bolts (sold separately). Be sure that the brackets are level and vertically aligned with one another.

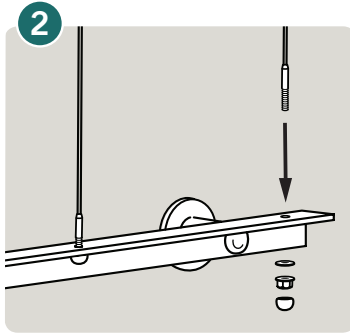

Attach and tighten the vertical cables. Threaded Terminal fittings on the bottom and QuickConnect-SS™ fittings on top.

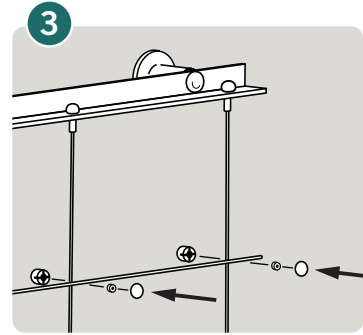

Position and fasten the horizontal rods to the cable using the Cross-Clamps with locking setscrews.

Installing Your Greenway® Trellis.

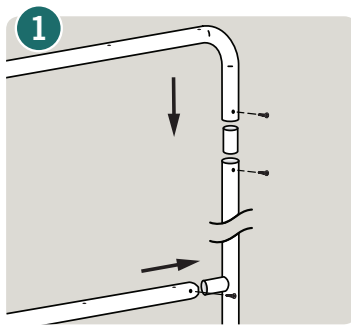

On a flat, soft surface assemble the tubular frame using splice sleeves and screws.

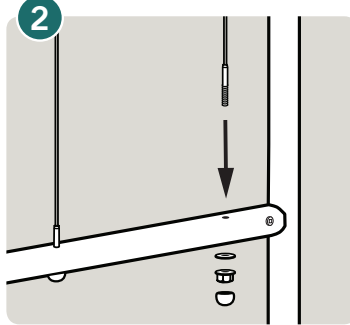

Attach and tighten the vertical cables. Threaded Terminal fittings on the bottom and Fixed Button Head fittings on top.

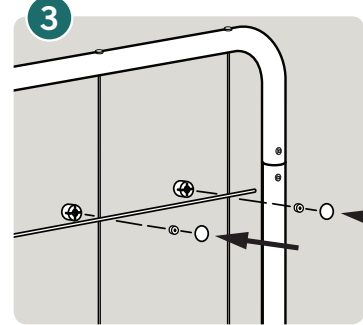

Position and fasten the horizontal rods to the cable using the Cross-Clamps with locking setscrews.

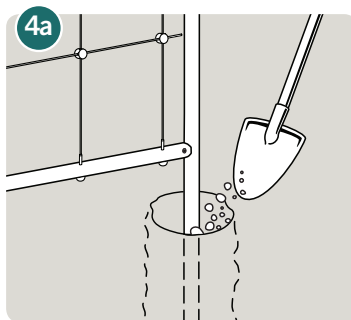

Dig holes and lift the trellis frame into position. Carefully fill the holes with gravel or concrete; check alignment frequently.

or

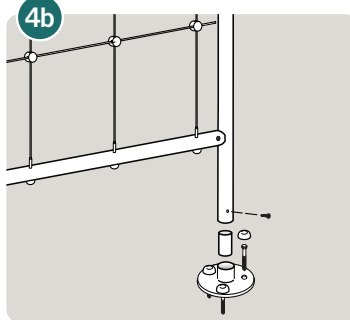

Trim legs to desired length and attach base plates (sold separately). Lift frame into position and securely bolt or screw plates to floor or deck surface.

2 YEAR LIMITED WARRANTY

Feeney Inc (Feeney) warrants that all CableTrellis™ trellis kits (aluminum support frames and stainless steel cables, rods and connectors) shall be free from defects in material and workmanship under normal use, conditions, installation and maintenance in accordance with product specifications for two (2) years from date of purchase. The complete text of this warranty is available on our website www.cabletrellis.com.

IMPORTANT NOTE: Never attach trellises to vinyl siding, stucco, Dryvit® or other synthetic or natural construction material walls where the structural integrity is uncertain or where possible penetration of a moisture barrier membrane may create a potential for water leakage or damage or may violate and void any product warranties. Be sure to carefully seal any wall penetrations with the proper sealant materials. Consult a construction expert for advice on your specific conditions.

Building codes vary by state, county and city, so be sure to consult with your local building department before starting your project.

Accessory Items



CABLE CUTTERS

- For trimming excess cable on the Somerset® Trellis

Part #	Cable Size	Length
2972-pkg	Up to 1/8"	7-1/2"



BASE PLATE KITS

- For converting the Greenway® Trellis to base mounting
- Trim both trellis legs to the desired length; insert base plates and secure with locking screws. Trellis can then be attached to a flat horizontal surface using bolts or screws
- Each kit includes 2 base plates, 2 lock screws, 6 retaining washers and 6 plastic caps for covering the attachment bolt/ screw heads (bolts and screws sold separately)
- Aluminum with powder-coated finish

Part #	Description
8450	Base Kit with pair of 5" diameter plates



ROD & CROSS-CLAMP KITS

- For attaching additional horizontal stainless steel rods to your trellis grid
- Each kit comes with 1 rod, 4 Cross-Clamps (choose either hard-anodized aluminum or stainless steel) and 4 plastic caps (Stainless Steel Caps are available as an optional item)
- Rods are 1/8" diameter x 38-1/4" long

Part #	Description
8430	Rod kit with hard-anodized cross-clamps
8435	Rod kit with stainless steel cross-clamps

STAINLESS STEEL CAPS

- Decorative option for covering the Cross-Clamp setscrew
- Caps snap on without any tools

Part #	Description
3372	Dome
3373	Crown
3374	Chamfer



STAINLESS STEEL HEX HEAD LAG SCREWS

- For attaching trellises to wood structures

Part #	Size	Used On
7277	3/8" x 3-1/2"	Greenway® Base Plates
7278	3/8" x 6"	Somerset® Angle Brackets



STAINLESS STEEL BOLTS AND DROP-IN ANCHORS

- For attaching trellises to concrete, brick, masonry or block structures
- Drop-In anchors require a setting tool
- Bolts, anchors and setting tools are all sold separately

Part #	Description	Used On
7286	Hex Bolt, 3/8" x 1"	Base Plates
7287	Hex Bolt, 3/8" x 4"	Angle Brackets
7283	Drop-In Anchor, 3/8" Thrd x 1-9/16" OAL	3/8" Bolts (above)
7291	Anchor Setting Tool (Reusable)	3/8" Anchors



HOW TO ORDER

CABLETRELLIS™ KITS

1) Carefully Review: Read all product information provided in this catalog and on our website www.cabletrellis.com. If you have questions, please call our sales department for assistance, 1-800-888-2418.

2) Select Trellis Style: Wall mounted Somerset® Trellis or freestanding Greenway® Trellis.

3) Select Cross-Clamp: Hard-anodized aluminum or stainless steel.

4) Determine Size (Somerset® Only): Measure vertically the area you would like covered and order the nearest larger size kit. You can trim cables to exact size in the field.

5) Determine Quantities: Select the quantity of trellises needed.

6) Check Accessories: Make sure that you have all of the necessary accessories and tools.

7) Place Your Order: Please call, fax or e-mail us your final list for order processing. Orders ship via UPS.

FREE: 1-800-888-2418
PH: 1-510-893-9473
FAX: 1-510-893-9484
SALES@FEENEYWIRE.COM
WWW.CABLETRELLIS.COM

STA-LOK[®]

Stainless Steel Rod Assemblies Offer Strength, Versatility & Beauty.

Feeney has partnered with Sta-Lok[®], one of the world's leading manufacturers of high-quality rigging products since 1973, to offer a comprehensive range of stainless rods and fittings manufactured from the highest specification materials. Sta-Lok[®] rod assemblies are an attractive, high-strength, low-maintenance alternative to traditional steel rod and wire rope rigging systems, and they have the added benefit of being able to support loads in both tension and compression conditions. All assemblies are made to order, ready to install and can be used in a variety of structural and decorative applications from glass curtain wall and door canopy supports, to guardrail balusters and trellis infill grids.

- Available in 1/4" to 1" diameter sizes to meet a wide range of design applications
- Low-maintenance, weather-tough 316-grade stainless steel with a satin finish
- Tension Fork fittings offer easy adjustment without bulky turnbuckles
- Special Rod Connectors available for assemblies longer than 12 feet
- Variety of decorative and structural applications
- Cold-heading and other specialty rods and components are available as special order
- Easy ordering with most materials in stock and ready for fast turn-around and delivery
- 3-part specifications available at www.stalokrods.com
- Toll-free design detail and product selection assistance, 1-800-888-2418



Sta-Lok

Sta-Lok® Rods & Components

1-800-888-2418

feeneyarchitectural
PRODUCTS

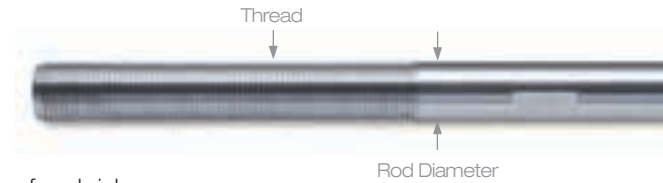

Stainless Steel Rods

- Custom cut and threaded to meet the specific requirements of each job
- Available in lengths up to 12 feet and in diameters to suit UNF threads 1/4" to 1"
- Rod Connectors are used for spans greater than 12 feet
- Milled wrench flats allow tools to grip the rod securely with minimal scratching
- Minimum breaking loads are based on the core diameter of the thread
- 316-grade stainless steel with a satin finish

ROD DIAMETER	THREAD UNF	BREAKING LOAD (LBS)	PROOF STRESS 0.2% (LBS)
*1/4"	1/4"	3217	1696
5/16"	5/16"	5170	2725
3/8"	3/8"	7943	4186
*7/16"	7/16"	10709	5664
1/2"	1/2"	14569	7678
5/8"	5/8"	23458	12363
3/4"	3/4"	31000	18083
*7/8"	7/8"	42384	24724
1"	1"	55103	32144

*Non-stock, special order item

Sta-Lok® Rod Connectors

- For linking two rod sections together to extend lengths beyond 12 feet
- Connectors are tapped LH threads on one end and RH threads on the other to ensure that assemblies will not unscrew during tensioning
- Designed to develop the full load of the rods
- Available in sizes to suit UNF threads 1/4" to 1"
- 316-grade stainless steel with a satin finish

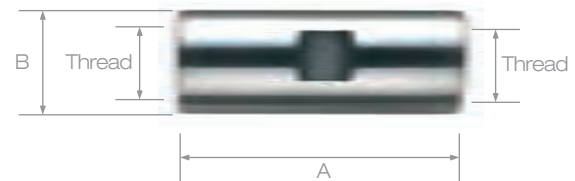

ITEM #	THREAD UNF (LH/RF)	A	B
*RC-14	1/4"	1-3/16"	3/8"
RC-516	5/16"	1-3/8"	7/16"
RC-38	3/8"	1-5/8"	9/16"
*RC-716	7/16"	1-15/16"	11/16"
RC-12	1/2"	2-3/16"	3/4"
RC-58	5/8"	2-5/8"	7/8"
RC-34	3/4"	3-1/8"	1-1/8"
*RC-78	7/8"	3-5/8"	1-1/4"
RC-100	1"	4-1/8"	1-3/8"

*Non-stock, special order item



Sta-Lok® Tension Forks

- Available with left-hand and right-hand UNF threads in 1/4" to 1" sizes
- Each fork comes with a locking Conical Nut (CN) and Double Headed Pin
- Using LH and RH threaded Tension Forks on a rod assembly alleviates the need for a turnbuckle and provides the most symmetrical design and economical method of tensioning
- Designed to support the full load of the rods
- 316-grade stainless steel with a satin finish

ITEM #	UNF THREAD	CN	A	B	C	D	PØ
*F34-03L/R	1/4"	7/8"	1-33/64"	25/64"	21/64"	1/4"	1/4"
F34-04 L/R	5/16"	1"	2-5/64"	37/64"	13/32"	5/16"	5/16"
F34-05 L/R	3/8"	1-1/8"	2-17/64"	45/64"	7/16"	3/8"	3/8"
*F34-06 L/R	7/16"	1-1/4"	2-33/64"	7/8"	5/8"	7/16"	7/16"
F34-08 L/R	1/2"	1-7/16"	2-45/64"	1-5/64"	3/4"	1/2"	1/2"
F34-10 L/R	5/8"	1-5/8"	3-27/64"	1-5/32"	57/64"	5/8"	5/8"
F34-12 L/R	3/4"	1-5/8"	4-7/32"	1-5/16"	1"	3/4"	3/4"
*F34-14 L/R	7/8"	2-3/8"	4-1/2"	1-1/2"	1-15/64"	7/8"	7/8"
F34-16 L/R	1"	2- 3/4"	5-7/64"	1-37/64"	1-25/64"	1"	1"

*Non-stock, special order item

L/R = left-hand / right-hand threads

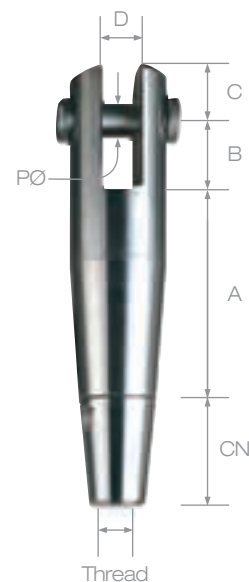

Sta-Lok® Isolation Washers and Sleeves

- Used to eliminate direct contact of dissimilar metals, thereby minimizing the possibility of electrolysis when attaching Tension Forks to structural members
- Isolation Washers are made from nylon and Isolation Sleeves are made from glass filled nylon for extra high compression strength and durability
- All Washers and Sleeves are special order items



Sta-Lok[®] Rod Assemblies

Sta-Lok[®] Tension Fork Rod Assemblies

In addition to individual rods and components, Feeney offers complete rod assemblies made to your exact lengths, ready to install. Assemblies come with a left-hand Tension Fork on one end and a right-hand Tension Fork on the other, affording easy adjustment and tensioning without the need for bulky in-line turnbuckles. Simply spin the rod to adjust length. Wrench flats are machined onto each rod so that wrenches can grip without scratching the finish. Assemblies are manufactured to your exact lengths with the Tension Forks set in the mid-adjustment position, allowing maximum adjustment without any exposed threads. See chart below for the plus/minus adjustment for each rod size.

- Each assembly includes a rod, LH and RH Tension Forks, Conical Nuts, Double Headed Clevis Pins and Rod Connectors (if needed)
- Manufactured from 316-grade stainless steel with a satin finish
- Available in 1/4" to 1" diameters
- Rod Connectors are used for all assemblies over 12 feet long
- Assemblies are shipped pre-assembled, with Tef-Gel anti-seize on the threads

Measuring Assembly Lengths

Assemblies are measured from center pin to center pin with the Tension Forks set in the mid-adjustment position. The chart indicates the available plus/minus adjustment range for each rod size. Assemblies are designed so that no threads will ever be exposed if adjustment is kept within the noted ranges.

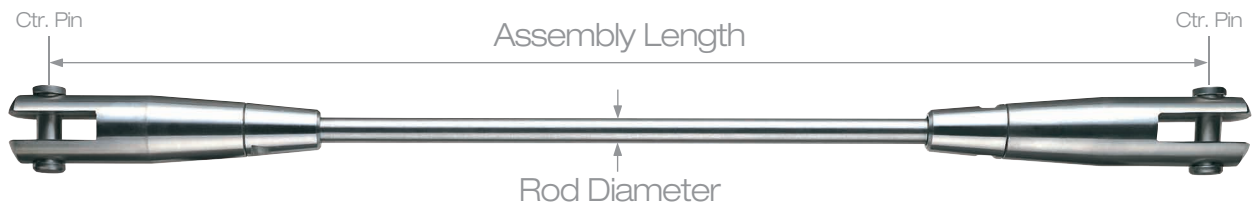

Sta-Lok[®] Tension Rod Assembly Standard Adjustment Ranges

Rod Diameter	Adjustment Each End	Adjustment Total Assembly
1/4"	+/- 1/4"	+/- 1/2"
5/16"	+/- 5/16"	+/- 5/8"
3/8"	+/- 3/8"	+/- 3/4"
7/16"	+/- 7/16"	+/- 7/8"
1/2"	+/- 1/2"	+/- 1"
5/8"	+/- 5/8"	+/- 1-1/4"
3/4"	+/- 3/4"	+/- 1-1/2"
7/8"	+/- 7/8"	+/- 1-3/4"
1"	+/- 1"	+/- 2"

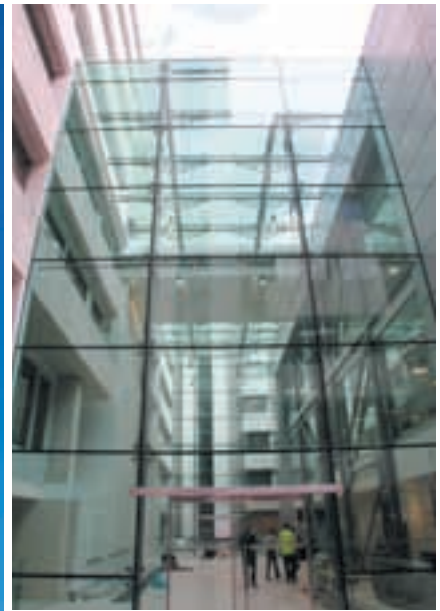
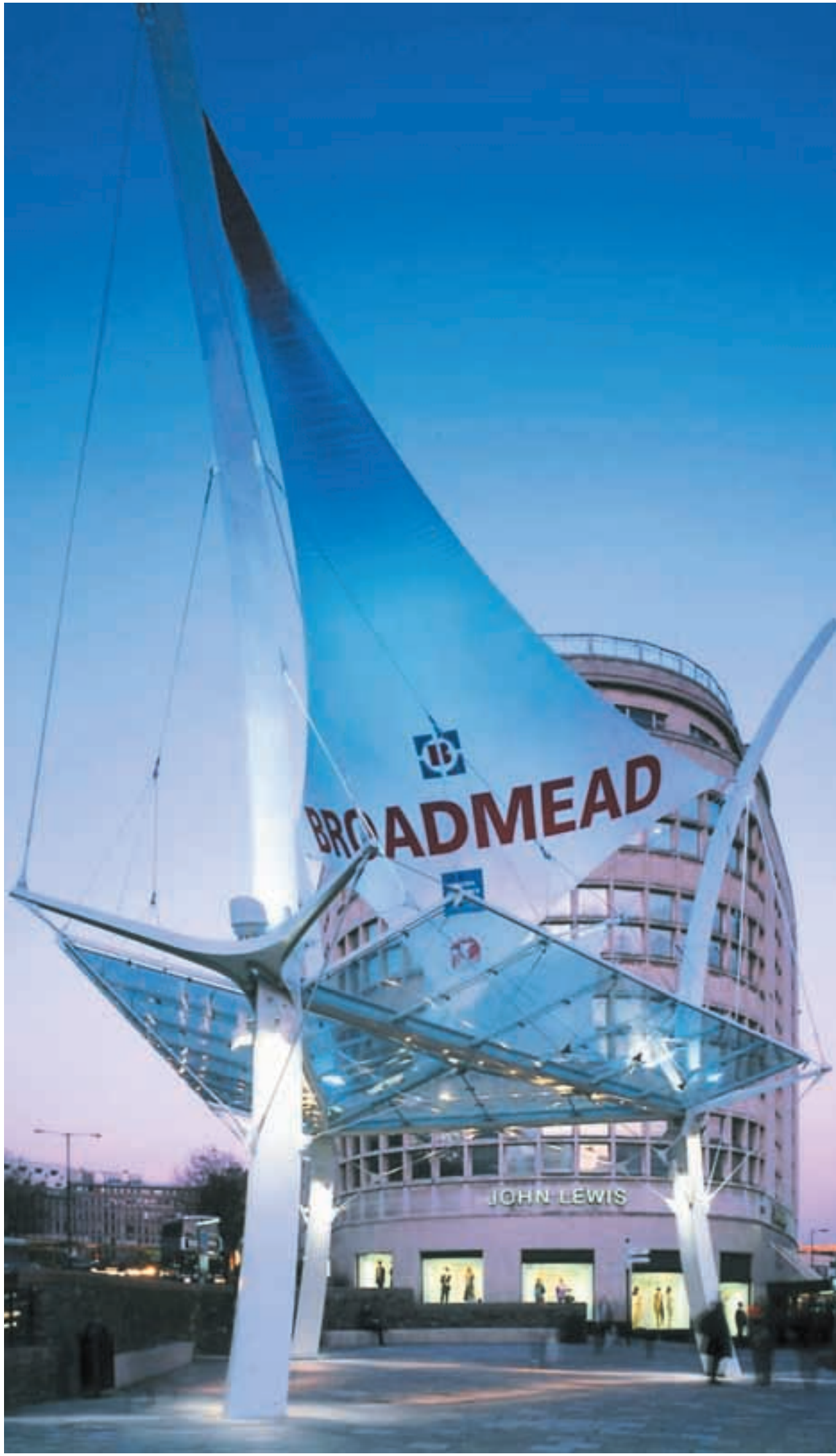

Sta-Lok



Installing Your Sta-Lok® Rod Assemblies.

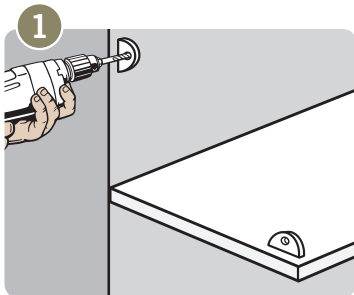

1 Mark and drill holes in the framework (or install eyebolts). Be sure the material thickness, hole diameter and hole position allow for the fork opening and clevis pin to fit properly.

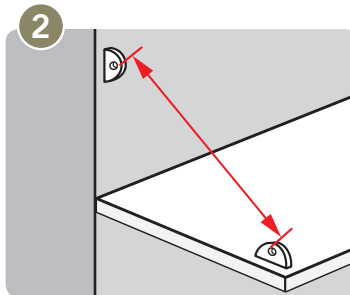

2 Measure between the bearing edges of the attachment holes and calculate the assembly lengths for ordering.

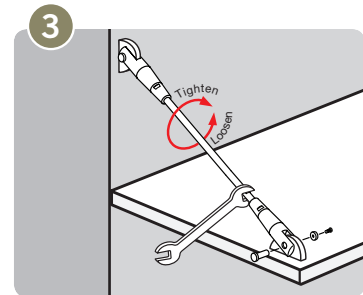

3 Loosely attach the rod assembly by fastening the fork ends to each hole using the removable clevis pins. If necessary, spin both forks equally to adjust length. Adjust final tension by turning the rod with a wrench.



2 YEAR LIMITED WARRANTY

Feeney Inc (Feeney) warrants that all Sta-Lok® stainless steel rods and connectors shall be free from defects in material and workmanship under normal use, conditions, installation and maintenance in accordance with product specifications for two (2) years from date of purchase. The complete text of this warranty is available on our website www.stalokrods.com.

HOW TO ORDER STA-LOK® ROD COMPONENTS AND ASSEMBLIES

- 1) Carefully Review:** Read all information provided in this catalog and on our website www.stalokrods.com. For questions and assistance, please call our sales department toll-free, 1-800-888-2418.
- 2) Select Fittings and Sizes:** Select the diameter of rod and type of fittings needed for your project application.
- 3) Measure Lengths:** Calculate the center pin to center pin lengths for each of your assemblies.
- 4) Determine Quantities:** Count the number of assemblies you will need.
- 5) Check Accessories:** Note any isolation sleeves, washers or connectors you may require.
- 6) Confirm Details and Prices:** All projects are unique. Call us at 1-800-888-2418, and our staff will assist you in confirming a list of the parts needed for your project and provide you with a price quote.
- 7) Place Your Order:** Please call, fax or e-mail us your final list for order processing. Standard orders ship via common truck carrier, freight collect.

FREE: 1-800-888-2418
PH: 1-510-893-9473
FAX: 1-510-893-9484
SALES@FEENEYWIRE.COM
WWW.STALOKRODS.COM

IMPORTANT NOTE

Building codes vary by state, county and city, so be sure to consult with your local building department before starting your project.



Flair & Functionality for your doorways.

Feeney introduces the new Lightline® Canopy products manufactured by Polymer Kunststoffe GmbH of Germany. LightLine® Canopies combine stainless steel, aluminum and acrylic components into modern, eye-catching designs that are both visually and functionally attractive. The canopies are sold in easy-to-order, fast-to-assemble kits with durable, weather-tough stainless steel support arms, UV resistant acrylic visor panes, integrated aluminum rain gutters and all of the necessary attachment hardware. Kits come in three styles and a variety of sizes with clear or frosted pane finish options, and the special patented Click-Lock pane attachment feature makes installation a breeze.

- Easy-to-order, easy-to-install kits in a variety of styles and sizes
- Slim stainless steel support arms with a fine grain satin finish
- 4mm (5/32") acrylic visor panes in clear or frosted finishes
- Integrated clear-anodized aluminum rain gutters
- Clear-anodized aluminum wall connection with hidden rubber seal
- Patented Click-Lock pane attachment feature for easy installations
- German engineering and quality
- Toll-free information and assistance line, *1-800-888-2418*

1-800-888-2418

feeneyarchitectural
P R O D U C T S



Lightline® Specifications

Curve Canopy

The Lightline® Curve Canopy is the simplest and most popular style with a design that gently slopes away from the wall.

- Kits come in four size models: (1500, 1900, 2700 and XL) and include all of the necessary installation hardware
- A hidden rubber gasket seals the canopy to the wall surface and directs rainwater down the curved pane into an integrated front gutter
- Support arms with special Click-Lock pane attachment feature create a strong, durable and weather-tight structure
- 4mm (5/32") thick UV resistant acrylic visor pane is available in clear or frosted finishes. XL-Curve pane is 6mm (1/4") thick
- Support arms are 304-grade stainless steel with a fine sand satin finish; gutters are clear-anodized aluminum with stainless steel end caps

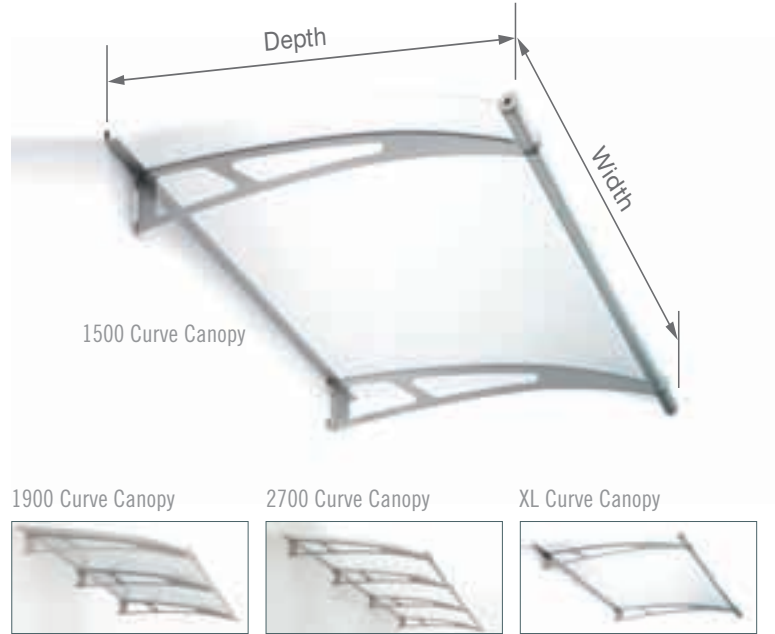

Model	Part#	Acrylic Pane	Qty Wall Brackets	Width	Depth
1500-Curve	9000-CLR	Clear	2	1500mm (4' 11-1/16")	950mm (3' 1-3/8")
1500-Curve	9000-FRS	Frosted	2	1500mm (4' 11-1/16")	950mm (3' 1-3/8")
1900-Curve	9001-CLR	Clear	3	1900mm (6' 2-13/16")	950mm (3' 1-3/8")
1900-Curve	9001-FRS	Frosted	3	1900mm (6' 2-13/16")	950mm (3' 1-3/8")
2700-Curve	9002-CLR	Clear	4	2700mm (8' 10-15/16")	950mm (3' 1-3/8")
2700-Curve	9002-FRS	Frosted	4	2700mm (8' 10-15/16")	950mm (3' 1-3/8")
XL-Curve	9003-CLR	Clear	2	2050mm (6' 8-11/16")	1420mm (4' 7-7/8")
XL-Curve	9003-FRS	Frosted	2	2050mm (6' 8-11/16")	1420mm (4' 7-7/8")

1-800-888-2418

feeneyarchitectural
P R O D U C T S



Arch Canopy

The Lightline® Arch Canopy covers your doorway with an elegant, modern archway.

- Kits come in two size models (1500 and 1900) and include all of the necessary installation hardware
- A rubber gasket on the edge of the acrylic pane seals the canopy to the wall surface and directs rain away from the wall and into two integrated side gutters
- Support arms with special Click-Lock pane attachment feature create a strong, durable and weather-tight structure
- 4mm (5/32") thick UV resistant acrylic visor pane is available in clear or frosted finishes
- Support arms are 304-grade stainless steel with a fine sand satin finish; gutters are clear-anodized aluminum with stainless steel end caps

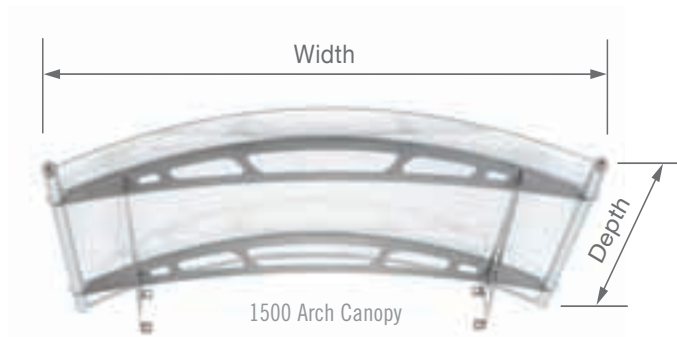

1900 Arch Canopy

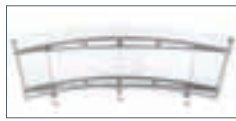

Model	Part#	Acrylic Pane	Qty Wall Brackets	Width	Depth
1500-Arch	9004-CLR	Clear	2	1480mm (4' 10-1/4")	910mm (2' 11-13/16")
1500-Arch	9004-FRS	Frosted	2	1480mm (4' 10-1/4")	910mm (2' 11-13/16")
1900-Arch	9005-CLR	Clear	3	1900mm (6' 2-13/16")	910mm (2' 11-13/16")
1900-Arch	9005-FRS	Frosted	3	1900mm (6' 2-13/16")	910mm (2' 11-13/16")

Gable Canopy

The Lightline® Gable Canopy is a contemporary spin on the beautiful pitched roof design.

- Kits come in two size models (1500 and 1900) and include all of the necessary installation hardware
- A rubber gasket on the edge of the acrylic panes seals the canopy to the wall surface and directs rain away from the wall and into two integrated side gutters
- Support arms with special Click-Lock pane attachment feature create a strong, durable and weather-tight structure
- 4mm (5/32") thick UV resistant acrylic visor panes are available in clear or frosted finishes
- Support arms are 304-grade stainless steel with a fine sand satin finish; gutters are clear-anodized aluminum with stainless steel end caps

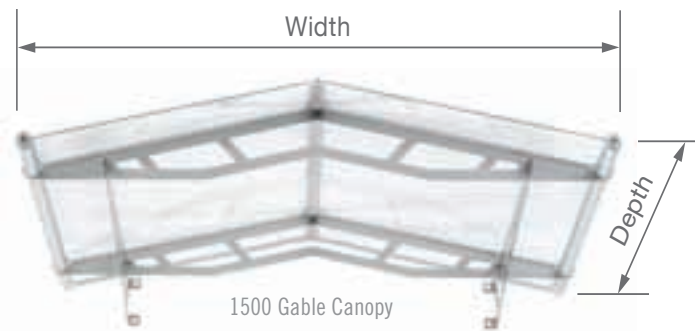

1900 Gable Canopy



Model	Part#	Acrylic Pane	Qty Wall Brackets	Width	Depth
1500-Gable	9006-CLR	Clear	2	1480mm (4' 10-1/4")	910mm (2' 11-13/16")
1500-Gable	9006-FRS	Frosted	2	1480mm (4' 10-1/4")	910mm (2' 11-13/16")
1900-Gable	9007-CLR	Clear	3	1900mm (6' 2-13/16")	910mm (2' 11-13/16")
1900-Gable	9007-FRS	Frosted	3	1900mm (6' 2-13/16")	910mm (2' 11-13/16")



Basic Steps For Installing The Curve Canopy.

Complete step-by-step installation instructions are available in PDF format on our website www.lightlinecanopies.com.



1
Align and attach the stainless support arms to the wall.

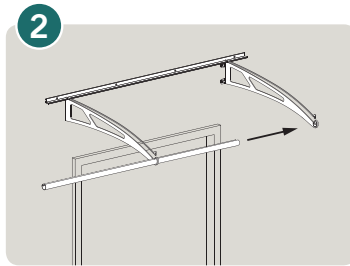

2
Insert the aluminum rain gutter through the slots at the end of the support arms.

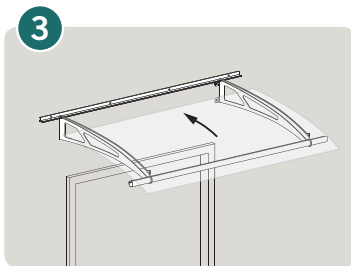

3
Slide the acrylic pane into position on the open support arms.

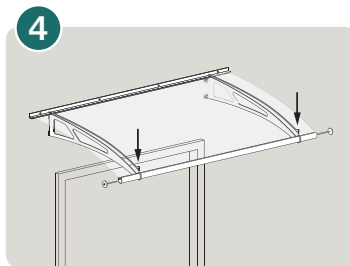

4
Secure the pane by closing the Click-Locks and attaching the rain gutter rods and end caps.

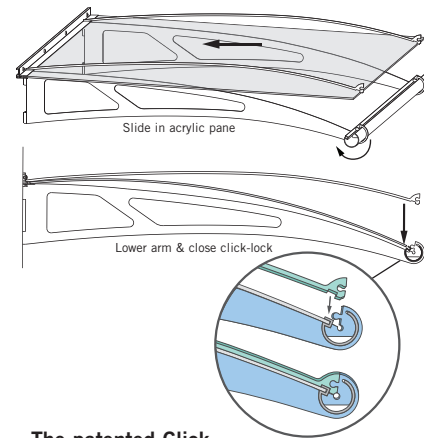

The patented Click-Lock feature eliminates the need to drill holes in the acrylic visor panes. Simply insert the acrylic pane into the frame, lower the support arms and snap the Click-Lock ends together. Secure and lock the arms and pane by attaching the special rain gutter rods and end caps.

Basic Steps For Installing The Arch Canopy.

(Gable Canopy is similar)

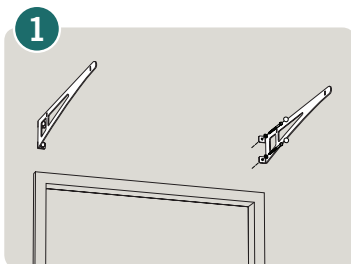

1
Align and attach the stainless support arms to the wall.

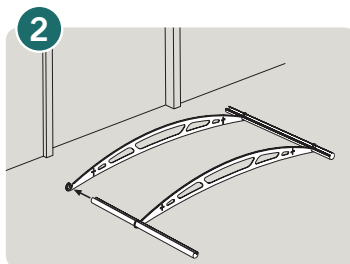

2
On a flat surface, assemble the main framework by inserting the rain gutters through the slots at both ends of the cross-members.

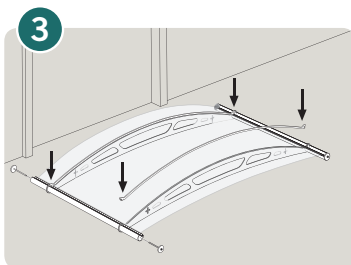

3
Set the acrylic pane(s) into position on top of the cross-members. Secure the locking arms by closing the Click-Locks and attaching the rain gutter rods and end caps.

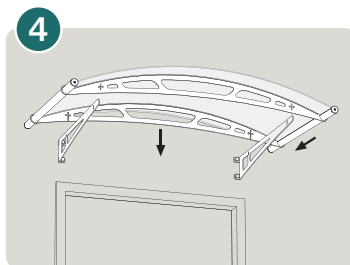

4
Lift the entire assembled framework onto the wall support arms and bolt in place.

IMPORTANT NOTES

Lightline® canopy kits come with all the hardware needed to assemble. Please verify the type of wall you have before installing the canopy. If necessary, you may need to use screws and anchors other than those included in the installation kit. Never attach canopies to vinyl siding, stucco, Dryvit® or other synthetic or natural construction material walls where the structural integrity is uncertain or where possible penetration of a moisture barrier membrane may create a potential for water leakage or damage or may violate and void any product warranties. Be sure to carefully seal any wall penetrations with the proper sealant materials. Consult a construction expert for advice on your specific conditions.

Building codes vary by state, county and city, so be sure to consult with your local building department before starting your project.



A FEW WORDS ABOUT THE MATERIALS

The protective chromium oxide film on the surface of stainless steel gives it superior corrosion resistance. Properly maintained stainless steel provides excellent luster, strength and durability. In most applications, stainless steel will not rust or stain even after years of service, but it is NOT rust or stain proof. When stainless comes in contact with chloride salts, sulfides or other rusting metals, it can discolor or even rust and corrode. With proper care and maintenance, however, stainless steel can remain beautiful and functional for years to come.

The acrylic panes have excellent resistance to weather and UV rays, but prolonged exposure to direct sunlight and environmental contaminants may cause slight discoloration over time. The panes are also subject to scratching. Therefore, it is important to install and handle the panes carefully and clean them properly. Please note that the Click-Lock installation feature also makes it very easy to replace panes if they were ever damaged. For complete care and maintenance instructions, please visit our website www.lightlinecanopies.com.

5 YEAR LIMITED WARRANTY

Feeney Inc (Feeney) warrants that all Lightline® canopy components (e.g. stainless steel support arms, aluminum gutters and acrylic panes) shall be free from defects in material and workmanship under normal use, conditions, installation and maintenance in accordance with product specifications for five (5) years from date of purchase. The complete text of this warranty is available on our website www.lightlinecanopies.com.

HOW TO ORDER LIGHTLINE® CANOPIES

- 1) **Carefully Review:** Read all information provided in this catalog and on our website www.lightlinecanopies.com. For questions and assistance, please call our sales department toll-free, 1-800-888-2418.
- 2) **Select Your Canopy Style:** Curve, Arch or Gable.
- 3) **Select Canopy Size:** Models 1500, 1900, 2700 or XL for the Curve style and models 1500 or 1900 for the Arch and Gable styles.
- 4) **Select Acrylic Pane Finish:** Clear (CLR) or Frosted (FRS).
- 5) **Determine Quantities:** Count the number of kits you will need.
- 6) **Confirm Details & Prices:** All projects are unique. Call us at 1-800-888-2418, and our staff will assist you in confirming a list of all items needed for your project and provide you with a price quote.
- 7) **Place Your Order:** Please call, fax or e-mail us your final list for order processing. The 1500 models can ship via UPS and all others via common truck carrier.

FREE: 1-800-888-2418

PH: 1-510-893-9473

FAX: 1-510-893-9484

SALES@FEENEYWIRE.COM

WWW.LIGHTLINECANOPIES.COM



feeneyarchitectural P R O D U C T S™

Sales Locations

FEENEY INC.

2603 Union Street
Oakland, CA 94607
Free: 1-800-888-2418
Ph: 1-510-893-9473
Fx: 1-510-893-9484
Email: sales@feeneywire.com

FEENEY NORTHWEST LLC

1299 Ocean Street
Eugene, OR 97402
Free: 1-888-458-0624
Ph: 1-541-683-8122
Fx: 1-541-431-4518
Email: sales@feeneynw.com

FEENEY SOUTHWEST INC.

7950 Silverton Avenue, Suite 114
San Diego, CA 92126
Ph: 1-858-578-6773
Fx: 1-858-578-6772
Email: sales@feeneysw.com

Manufacturing Location

FEENEY MANUFACTURING INC.

3551 County Road F
Tekamah, NE 68061
Ph: 1-402-808-4301
Fx: 1-402-808-4304
Email: info@feeneymfg.com

