

CABLE RAILING

SIMPLIFIED

Installation Instructions for Fortress Vertical Cable Railing System with UB-05 Brackets and Fe²⁶ Posts

It is the responsibility of the installer to meet all code and safety requirements, and to obtain all required building permits. The deck and railing installer should determine and implement appropriate installation techniques for each installation situation. Fortress Railing Products and its distributors shall not be held liable for improper or unsafe installations.

Fortress Fe²⁶ Posts must always be secured to the deck framing. Fortress Fe²⁶ Posts should never be attached to only the deck boards.

Read Instructions Completely Before Starting Installation

Note

When cutting Fortress railing, it is very important to complete the following at cut points.

- Remove all metal shavings from the cut area
- File any sharp edges left by cutting. Thoroughly wipe and remove any filings, grime or dirt from the railing.
- Apply two coats of Fortress zinc based touch-up paint to the cut area. If touch up is at rail ends, allow paint to dry before connecting bracket to post.
- Be sure to remove any metal shavings from the surface of deck, patio or balcony to prevent stains on the deck surface.

Torx Safety Tips

- Always pre-drill holes with a 3/16" drill bit.
- Always use the lowest speed setting on drill to reduce chance of bit breakage.
- Start tightening with drill on low torque setting and work up until screw is secured.

Required Materials

Portable Band Saw or Metal Cutting Reciprocating Saw, Drill, 3/16" Drill Bits, T-25 Driver Bit, Drill Bit Extender, Tape Measure, Socket Set, Speed Square, Hammer, Center Punch and Touch Up Paint

Mount Fe²⁶ Posts*

- Wood Blocking tied to deck frame must be installed and constructed with treated dimensional lumber with a minimum thickness of 1-1/2".
- Position the edge of Fe²⁶ Post base plate a minimum of 1/2" from the inside edge of rim joist.
- Mount Fe²⁶ Posts at appropriate points based on panel length.
- Attach Fe²⁶ Posts with 3/8" X 3-1/2" Hex Head Galvanized Bolts.

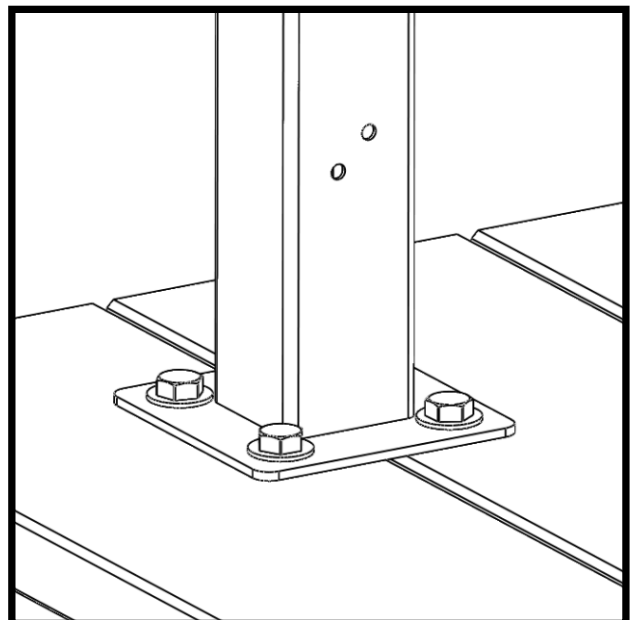
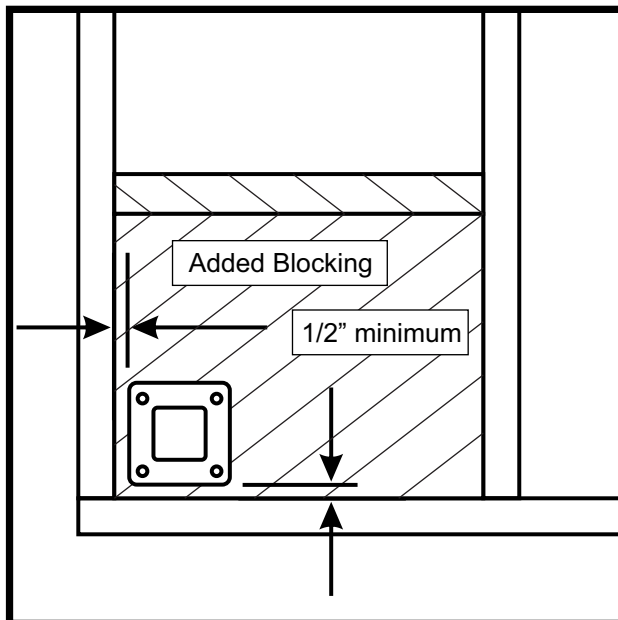

*Reference Fortress Fe²⁶ Post mounting instructions

For technical assistance, please email: technicalhelp@fortressrailing.com

Hours of Operation Monday through Friday 7:00 AM to 6:00 PM, CST

Phone: 844-909-2999 Fax: 972-372-0924

www.fortressrailing.com

Fortress Vertical Cable System Installation with Fe²⁶ UB-05 Brackets

Install Posts and UB-05 brackets. Brackets should be spaced according to the height of Fortress Vertical Cable Panel system being installed. Fortress Vertical Cable Panels are 34" or 40" systems.

Reference Fe²⁶ UB-05 instructions for bracket installation.

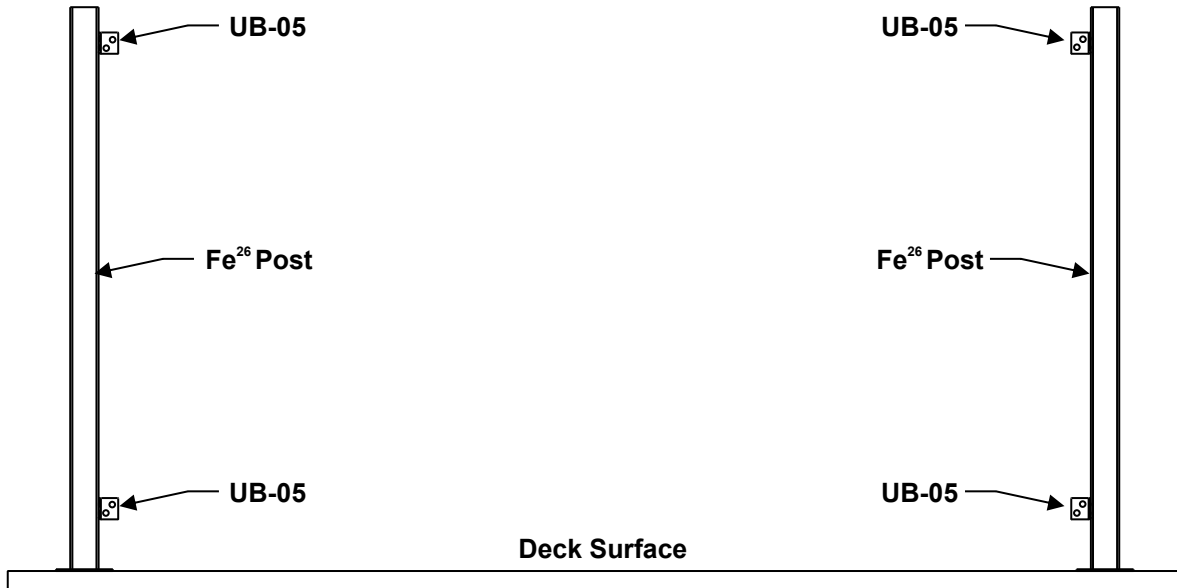

UB-05 Bracket Top and Bottom Locations for Fortress Vertical Cable System Installations

Pre-Drilling with a 3/16" drill bit is required.

Rail Panel Height	Pre-Drill Dimensions			
	A*	B	C	D
34"	3-5/8"	5-1/8"	36-3/8"	37-7/8"
40"	3-5/8"	5-1/8"	42-3/8"	43-7/8"

- *For proper cable railing installation and ease of tensioning, bracket spacing must be maintained.
- *Dimension A positions bottom edge of rail 3-3/4" above deck surface.
- *Dimension A is measured from the bottom surface of post base.

Remove all metal shavings from deck, post base cover, post, and panel before bracket is screwed to post to prevent rust stains.

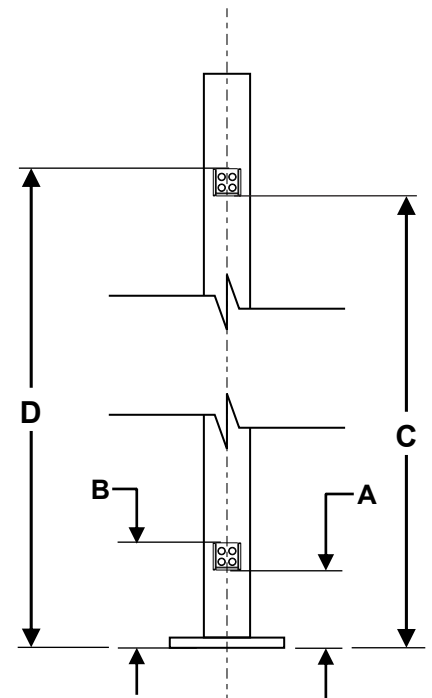

Measure and Cut Fortress Vertical Cable System

- Measure the distance between the installed UB-05 Brackets.
- Using a metal cutting blade, cut the rail at the four cutting mark locations from previous step. It is advisable to make a practice cut on a scrap piece of rail before proceeding with the finish cuts.
- Cut Rails so that there is an equal distance between the last cable and the end of rails.
- File cut edges and coat with 2 coats of Fortress zinc based touch-up paint.

Moving Cables and Vertical Supports

- Vertical Supports and Cables can be relocated to maintain even spacing.
- To remove a cable, completely remove the hex nut from the adjustable swage fitting located in the top rail and pull the cable assembly through the bottom rail.
- To remove a Vertical Cable support, completely remove the 8mm Hex bolt located in the top and bottom rail. Be sure to keep the washers for reinsertion of the bolts.
- Position the Vertical Cable support(s) so that they are centered or equally spaced across the panel span.
- Reinsert the Vertical Cable support(s) using the 8mm Hex bolt and washers in the desired location along the rail.
- For installations that span 24" or more Vertical Cable Supports are required.
- For installations with spans up to 6' one Vertical Cable Support is required.
- For installations with spans 6' to 8' two Vertical Cable Supports are required.

Install Fortress Vertical Cable I-Supports

- To install a Vertical Cable I-Support, replace the 8mm Hex bolt that secures the support to the bottom rail with the I-Support assembly. Be sure to keep the washer(s) as these will be required for proper installation of the I-Support.
- Hand tighten the I-Support to the Vertical Support and position counter sunk hole so that it is accessible.
- Secure I-Support to deck with the included #8 X 1.5" Flat Head Wood Screws.
- I-Supports are required for all installations in the Canadian market.
- I-Supports are not required for U.S. market, but available upon consumer request.

Install Fortress Vertical Cable System into the Fe²⁶ UB-05 Brackets

- Insert top and bottom rails into installed brackets.
- Using a 3/16" drill bit pre-drill the top and bottom rails at each UB-05 Bracket. Secure top and bottom rails to UB-05 Brackets with supplied T-25 Thread Cutting Screws. Only one screw is required to secure the rail at each UB-05 bracket.

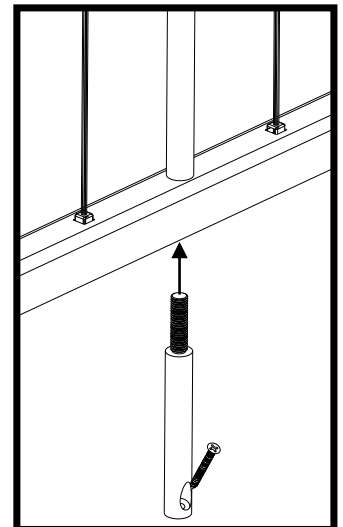
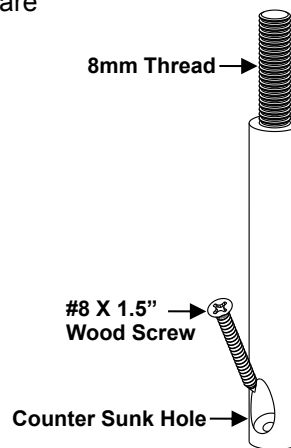
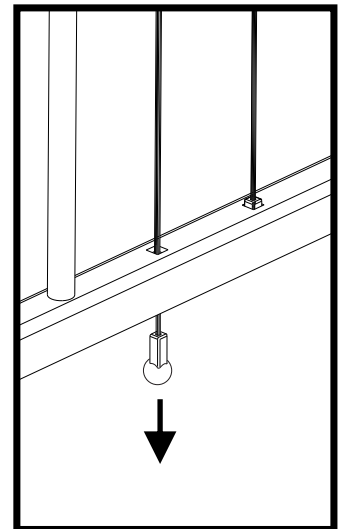
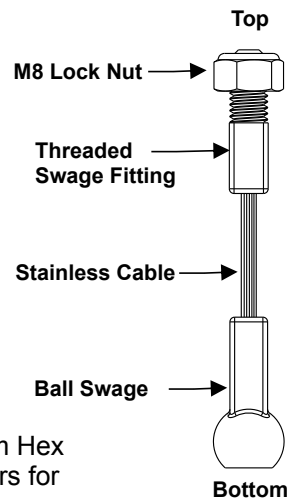
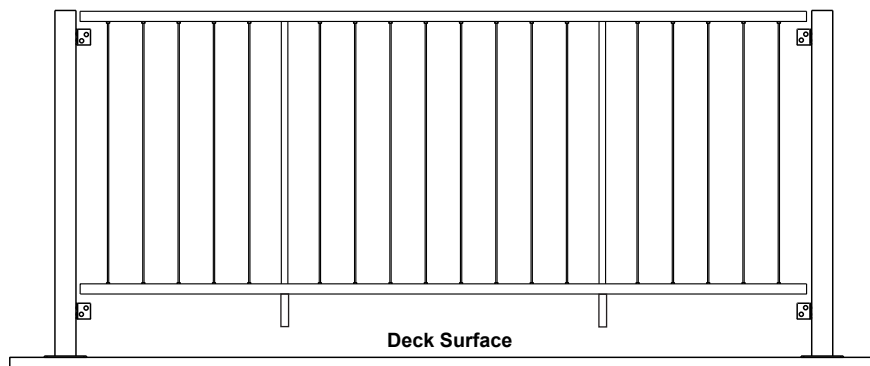

Tightening the Fortress Vertical Cable System

DO NOT Over Tighten Cables

- A properly tensioned cable should be tensioned until the indicator arrow reads between 10 and 16.
- Use a Fortress Cable Tension Gauge to accurately tension the cables.
- See images below for information on how to load cable into the tension gauge.
- Position cable between lower guides.
- Pull the lanyard and extend the spring until the cable is engaged with the hook in the indicator slide.
- The Fortress Vertical Cable Railing System uses **1/8" diameter cable**.
- Use a 13mm Socket Wrench to tighten the cables in the sequence shown below.
- Tighten cable until the indicator arrow is aligned between 10 and 16 on the tension gauge.

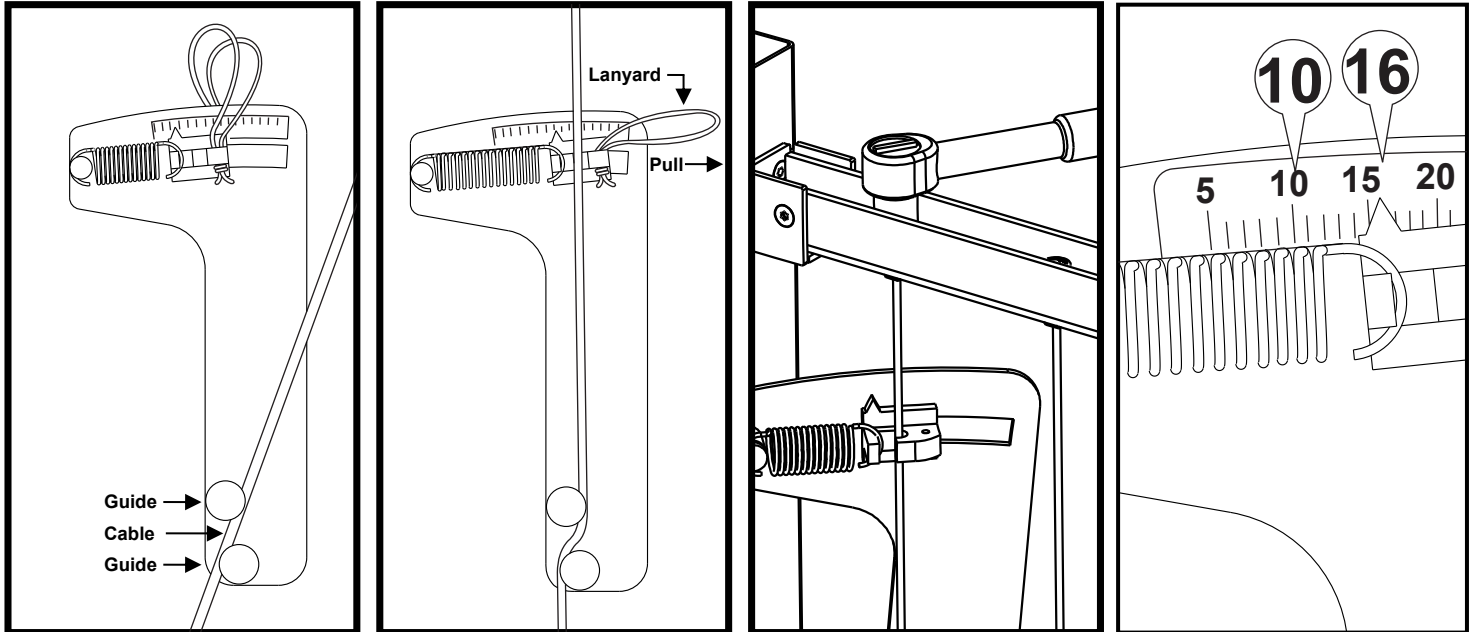

6' Rail Sequence

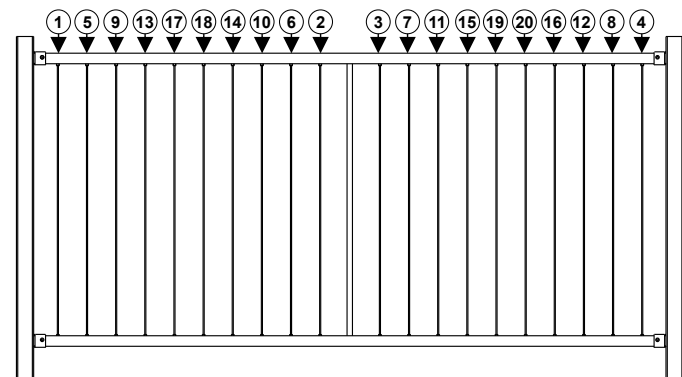

Cable Tensioning Sequence

Remove the slack from cables using the socket wrench, once the slack is removed, only tension the cables one turn at a time in the sequence shown to maintain even tensioning across the panel.

Once cables are tensioned to the proper range on the tension gauge you may move onto the next steps.

8' Rail Sequence

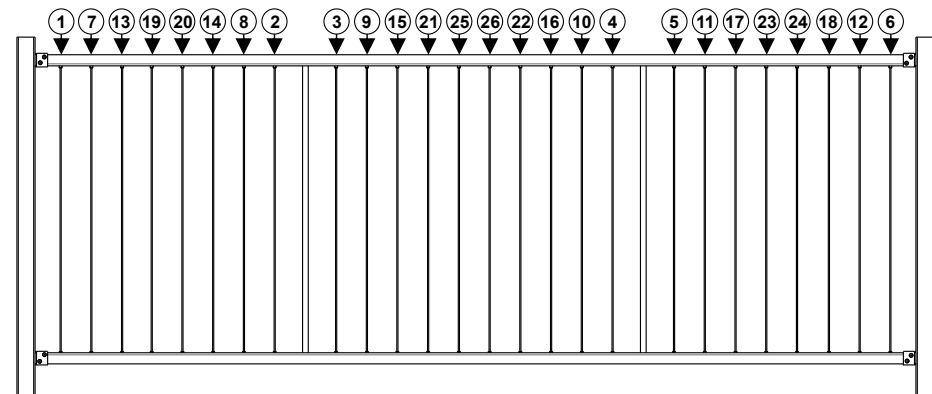

Install Flat Accent Top Rail (ATR) - Option 1

- Measure the distance between posts.
- A minimum of two ATR Spacers are required in order to ensure proper fit of ATR.
- Transfer that measurement to the ATR and cut a equal distance from each end of ATR. Check the fit of ATR.
- File any rough edges from cuts and apply zinc based touch up paint.
- Apply a quarter sized drop of epoxy to the side walls of each ATR Spacer. Follow cure times specified on epoxy packaging.
- Install ATR onto rail and wipe away any excess epoxy with a clean cloth.
- Let epoxy cure. Do not apply any force to installed ATR for 2 hours.

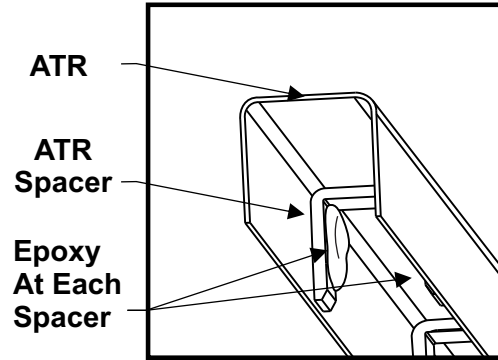
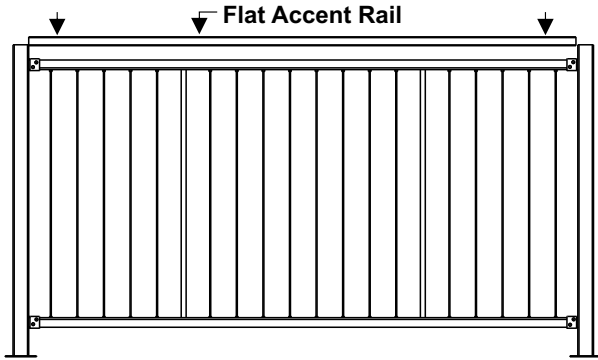

Install Wood or Composite Top Cap - Option 2

- Use a Wood Top Cap to finish the Top Rail.
- Cut Wood Top Cap to length and secure to Top Rail with Fortress Cap Rail Clips.
- Cap Rail Clips should be equally spaced along the length of Wood Top Cap (**Max Spacing is 28"**).

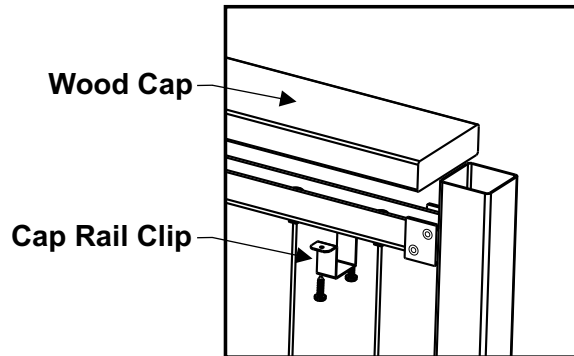
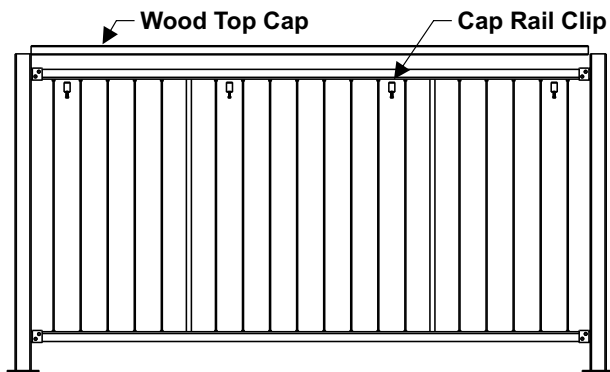

Install UB-05 Caps

- When using a Wood or Composite Top Cap and installing the UB-05 Caps on the Top Rail, the Caps should be installed upside down as shown.
- If using a Fortress Flat Accent Rail, UB-05 Caps will not be used on the Top Rail.

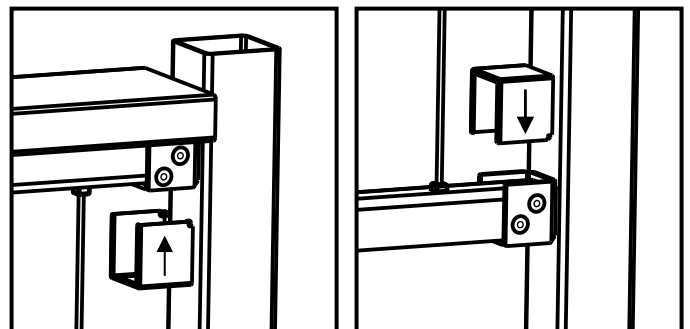
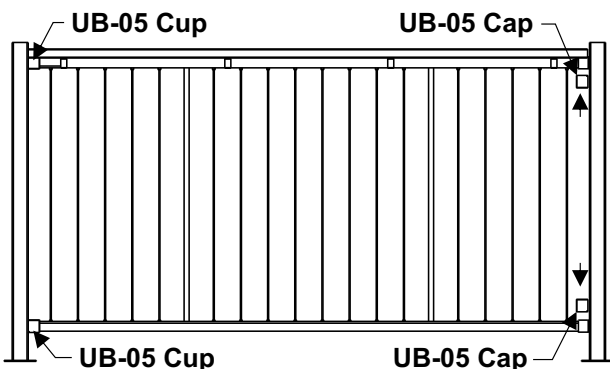

Installation Instructions for Fortress Vertical Cable Railing Stair Panel System with UB-05 With Angle Adapter and Fe²⁶ Posts

It is the responsibility of the installer to meet all code and safety requirements, and to obtain all required building permits. The installer should determine and implement appropriate installation techniques for each installation situation. Fortress Railing Products and its distributors shall not be held liable for improper or unsafe installations.

Fortress Fe²⁶ Posts must always be secured to the deck framing. Fortress Fe²⁶ Posts should never be attached to only the deck boards.

Read Instructions Completely Before Starting Installation

Note

When cutting Fortress railing, it is very important to complete the following at cut points:

- Remove all metal shavings from the cut area
- File any sharp edges left by cutting. Thoroughly wipe and remove any filings, grime or dirt from the railing.
- Apply two coats of Fortress zinc based touch-up paint to the cut area. If touch up is at rail ends, allow paint to dry before connecting bracket to post.
- Be sure to remove any metal shavings from the surface of deck, patio or balcony to prevent stains on the deck surface.

Torx Safety Tips

- Always pre-drill holes with a 3/16" drill bit.
- Always use the lowest speed setting on drill to reduce chance of bit breakage.
- Start tightening with drill on low torque setting and work up until screw is secured..

Required Materials

Portable Band Saw or Metal Cutting Reciprocating Saw, Fortress Cable Tension Gauge, Drill, 3/16" Drill Bits, T-25 Driver Bit, #2 Phillips Head Screw Driver, Drill Bit Extender, Tape Measure, Pencil, Socket Set, Speed Square, Hammer, Center Punch, Clamps, Support Blocks and Fortress Touch Up Paint

Removing Panel From Packaging

Installation of the Vertical Cable Railing Stair Panel requires an additional screw in each UB-05. The bag with the 4 screws is attached to the panel. **DO NOT DISCARD.**

The Vertical Cable Railing Stair Panel is packaged with a disposable upright at each end of the panel. Remove this upright only when you are ready to install the panel.

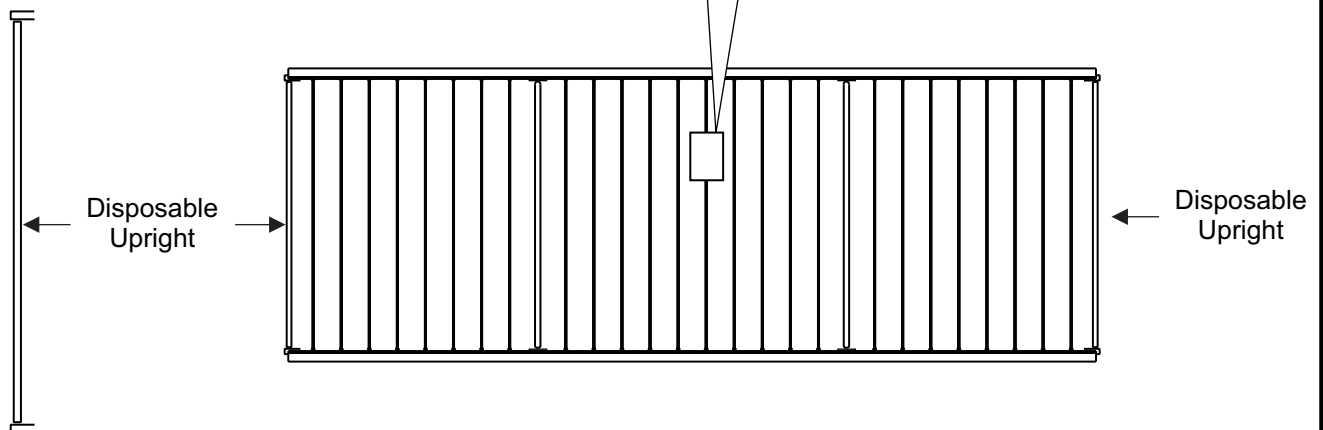
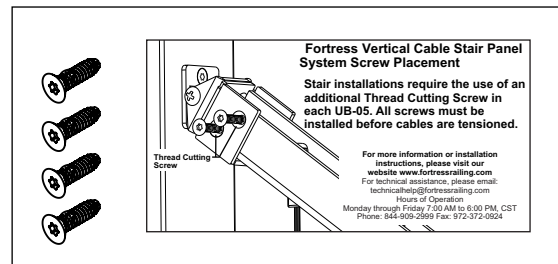

Vertical Cable Railing Stair Panel

Vertical Cable Railing Stair Panel 8' (actual length 93.5")

Available Heights 34" and 40"

Minimum angle is 30°

Maximum angle is 38°

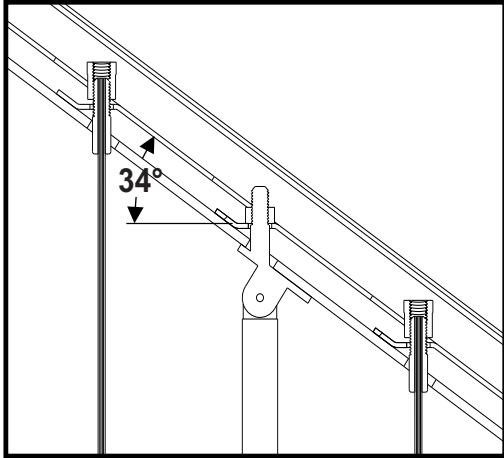

Vertical Cable Railing Stair Panels are designed with a nominal 34° of adjustability. The design allows for approximately 4° of adjustment in either direction. There will be a small amount of deflection in the cable at the stainless steel hardware.

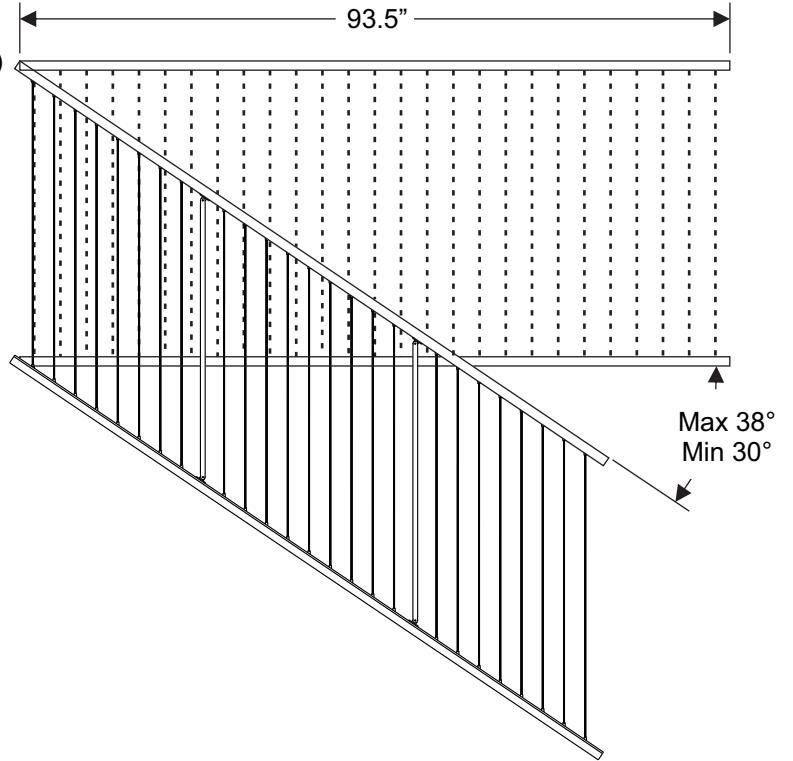

Fe²⁶ Posts for Stair Installations*

The installed location of Stair Posts is dependent on the rise and run of stairs and the railing height. When installing posts on stairs, we recommend not permanently installing Stair Posts until Panel Spacing and Angle are confirmed. Use Clamps to temporarily hold Stair Posts in place.

Mount Fe²⁶ Posts*

- Wood Blocking tied to deck frame must be installed and constructed with treated dimensional lumber with a minimum thickness of 1-1/2".
- Position the edge of Fe²⁶ Post base plate a minimum of 1/2" from the inside edge of rim joist.
- Mount Fe²⁶ Posts at appropriate points based on panel length.
- Attach Fe²⁶ Posts with 3/8" X 3-1/2" Hex Head Galvanized Bolts.

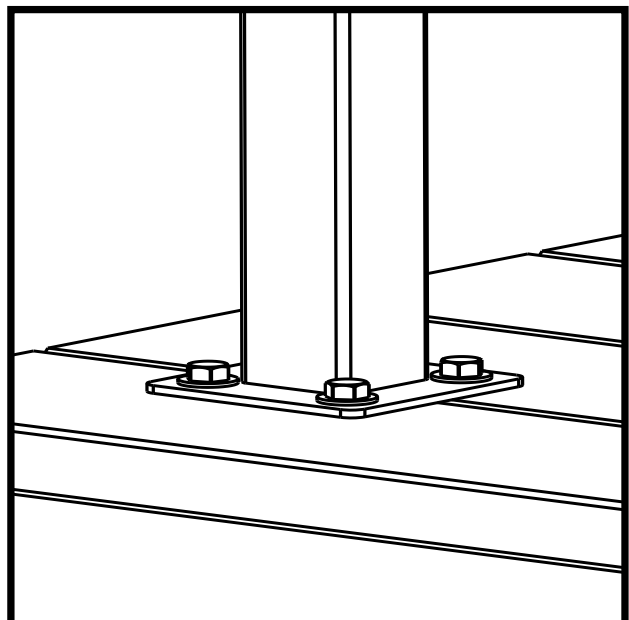
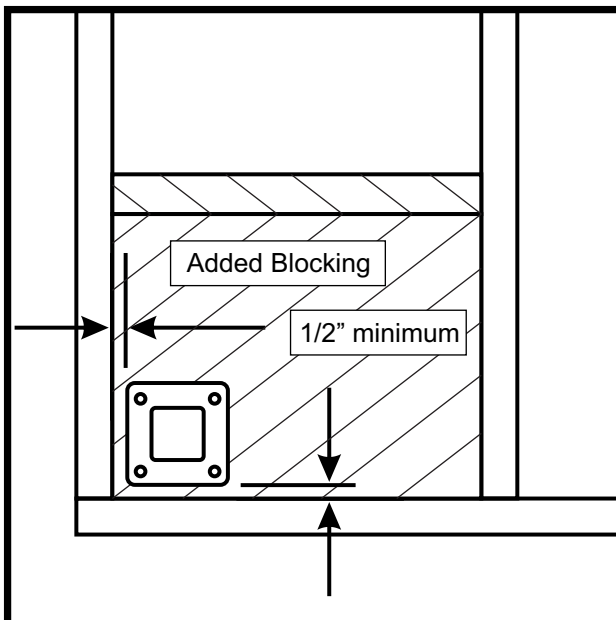

*Reference Fortress Fe²⁶ Post mounting instructions

Determine Rake and Center Panel Between Fe²⁶ Posts

This step requires two people.

Use Vertical Cable Railing Stair Panel to determine the angle of stair installation.

To do this use support blocks resting on the stair tread. Position support blocks so that the position of the bottom rail meets the spacing requirement of your local building code.

Adjust the panel so that the cables are parallel to the posts. Center the panel so that there is a equal distance between the edge of post and the first cable at each end of panel (Dimension A). **Dimension A must be greater than 2-1/4"**.

Vertical Supports and Cables can be relocated to maintain even spacing. To Remove Vertical Supports, **ALL** Cables must be loosened to allow for clearance of the Vertical Support bolts. To remove a cable, completely remove the extended hex nut located in the top rail and pull the cable assembly through the bottom rail.

Verify the position of the panel. With the help of another person, temporarily secure the panel to the posts with clamps.

Place a piece of cardboard between the clamping surfaces and the surfaces of the rails and posts to protect the finish.

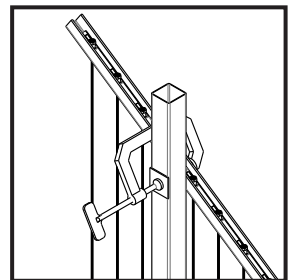
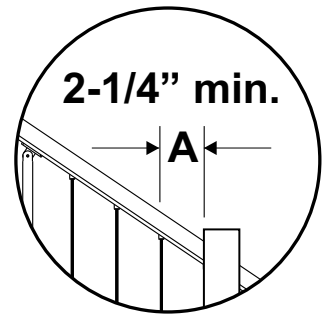
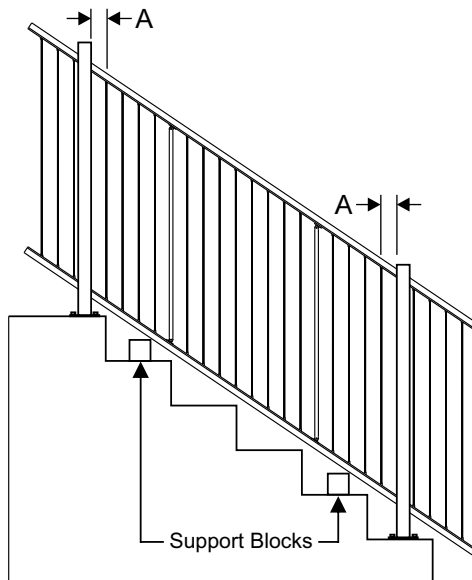

For Installations that span 24" to 60" a minimum of one Vertical Support is required. For installations 60" or greater two Vertical Supports are required.

Assemble Universal Bracket Angle Adapter Assembly and Mark Rail Length and Bracket Location.

- Assemble the Universal Bracket Angle Adapter Assembly to the Universal Bracket Cup with supplied screws. Do not over tighten hinge pin, as it will be temporarily removed in a later step.
- **BRACKET POSITION IS CRITICAL FOR A PROPERLY TENSIONED CABLE RAILING INSTALLATION**
- Place Universal Bracket Angle Adapter against post and position the cup so that it is parallel to the rail. With a pencil mark the position where the rail meets the back wall of the UB Cup on the top of the rail. With bracket in the same position mark the hole locations of the Post Plate on the post. **THE HOLES WILL NOT BE CENTERED ON THE POST. DO NOT DRILL HOLES AT THIS TIME.**
- Repeat this step for all four bracket locations.

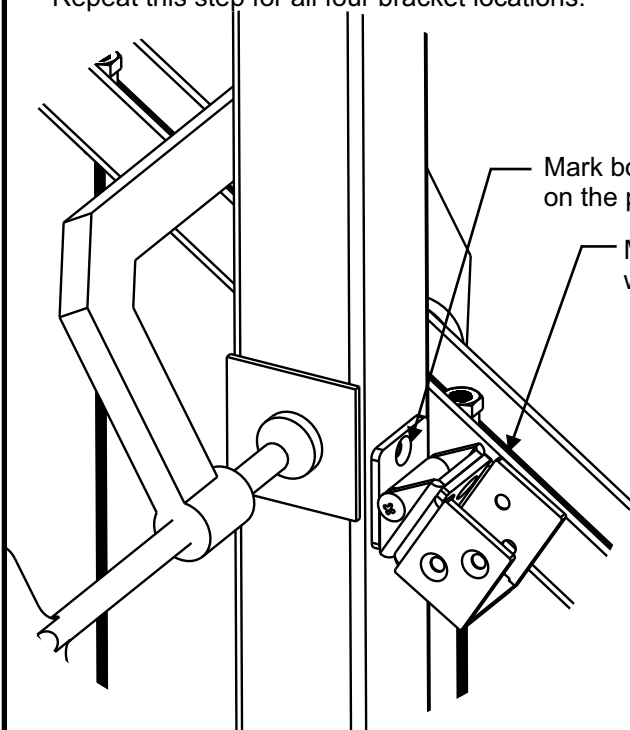

Mark both locations of the Post Plate Holes on the post.

Mark rail where it meets the back wall of UB Cup for cutting later

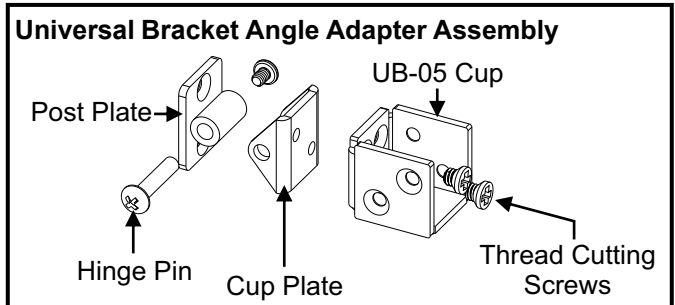

Pre-Drill and Install Universal Bracket Post Plates

- Remove c-clamps and panels.
- Mark the centerline of each post. The Universal Brackets will be installed on the centerline, not the locations marked in the previous step.
- Use a center punch and hammer to mark the hole locations and pre-drill all bracket hole locations with a 3/16" drill bit.
- Remove Hinge Pin from Universal Bracket Angle Adapter Assemblies.
- Attach Universal Bracket Angle Adapter Post Plates to post with supplied T-25 thread cutting screws.
- **Remove all metal shavings from surface, post base cover, post, and panel before bracket is screwed to post to prevent rust stains.**

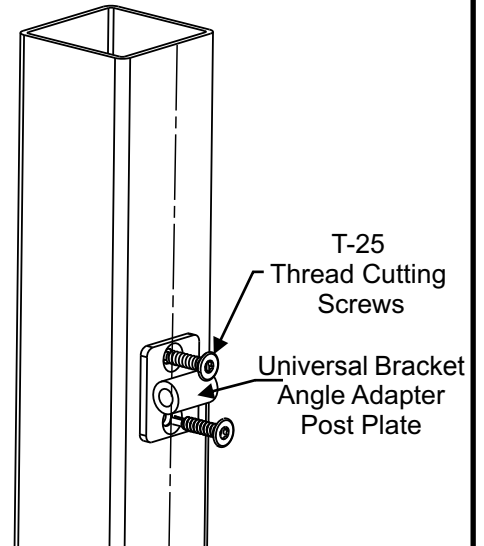
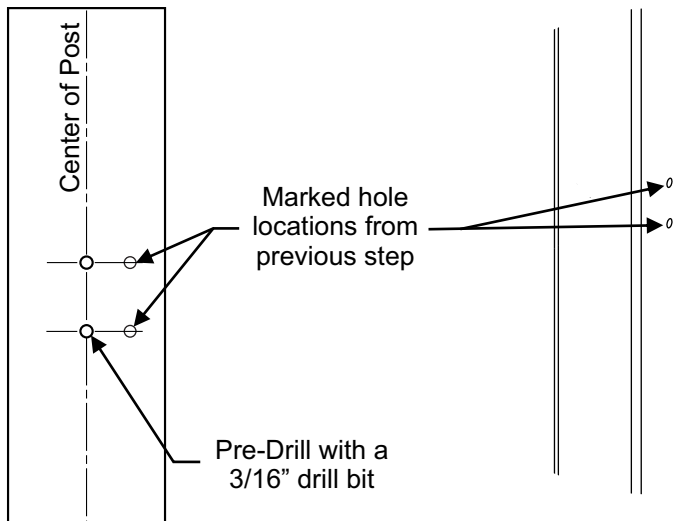

Cutting Vertical Cable Railing Stair Panel

- Lay panel on a flat surface.
- Using a portable bandsaw or a reciprocating saw, cut the rail at the four cutting mark locations from previous step. It is advisable to make a practice cut on a scrap piece of rail before proceeding with the finished cuts.
- **The distances from the first picket to the ends of the rail, will be different from the top to bottom rail. The greater the angle of the steps the more visible the difference will be. This is required in order to keep cables parallel to the post.**
- File cut edges. Remove metal shavings and coat with 2 coats of Fortress zinc based touch-up paint.

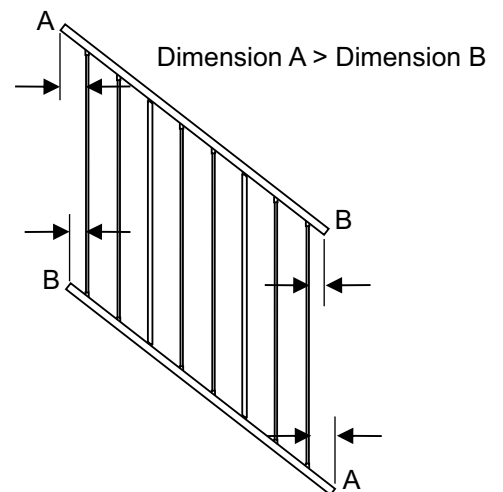
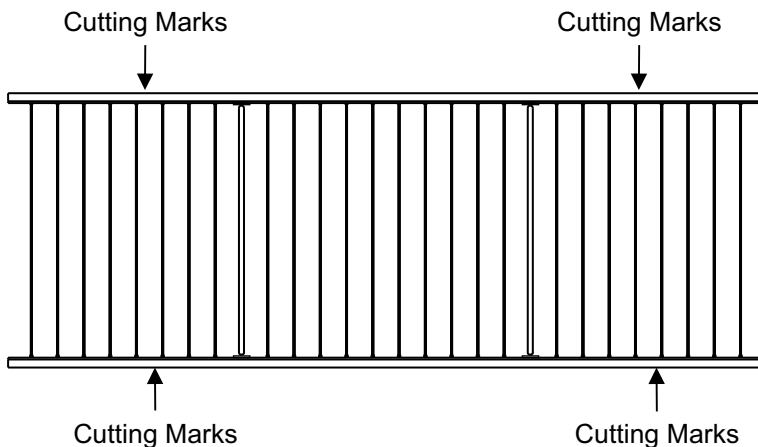
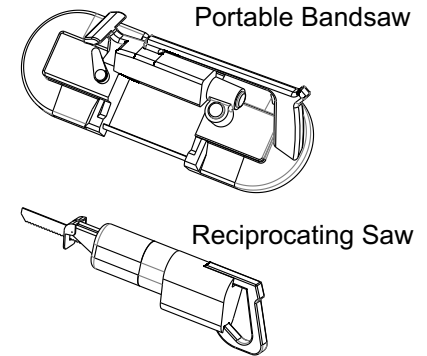

Install Panel

- Reassemble UB-05 Angle Adapter Assembly
- Reposition support blocks.
- Position Panel so that it aligns with the brackets. Use a clamp at each UB-05 to hold the panel in place.
- Check the fit of the panel and make any required adjustments.
- Pre-drill a 3/16" hole for each screw used to secure rail to UB-05.
- Remove any metal shavings from the inside of the rail.
- Secure panel to UB-05 with two T-25 Thread Cutting Screws in each UB-05. **For Vertical Cable Railing Stair Panels two T-25 Thread Cutting Screws are required at each bracket. The two screws must be installed on the same side of UB-05 as shown in the image below.**

Universal Bracket Angle Adapter Assembly

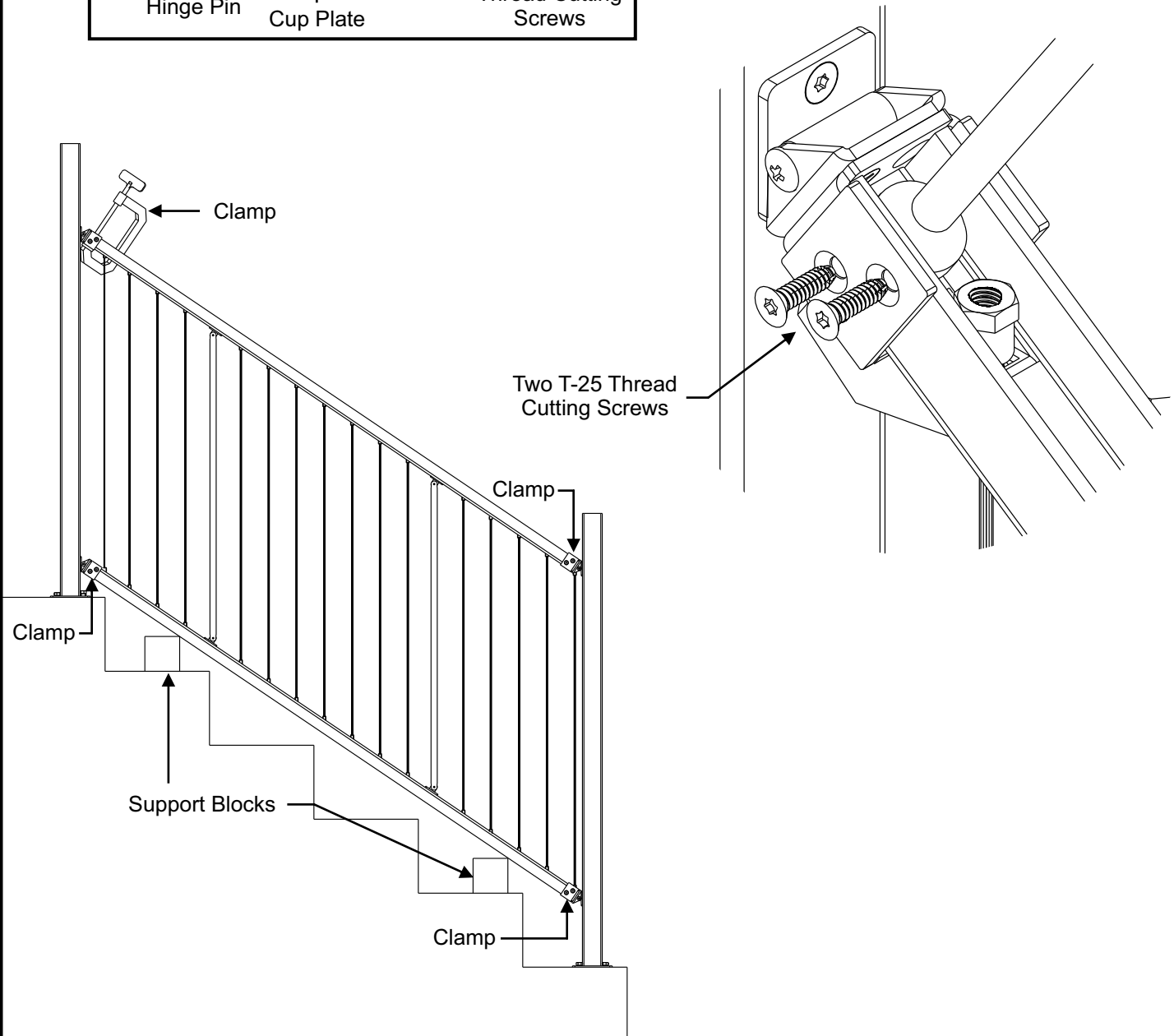
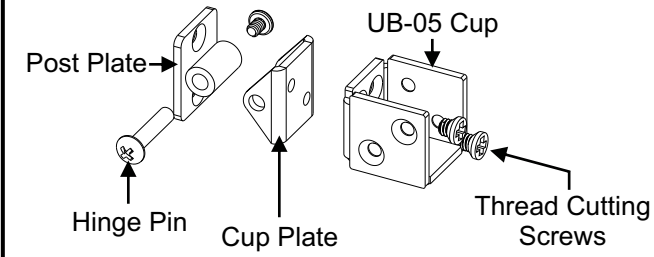

Tightening the Fortress Vertical Cable Railing System

DO NOT Over Tighten Cables

- A properly tensioned cable should be tensioned until the indicator arrow reads between 10 and 16.
- Use a Fortress Cable Tension Gauge to accurately tension the cables.
- See images below for information on how to load cable into the tension gauge.
- Position cable between lower guides.
- Pull the lanyard and extend the spring until the cable is engaged with the hook in the indicator slide.
- The Fortress Vertical Cable Railing System uses **1/8" diameter cable**.
- Use a 13mm Socket Wrench to tighten the cables in the sequence shown below to the right.
- Tighten cable until the indicator arrow is between **10** and **16** on the tension gauge.

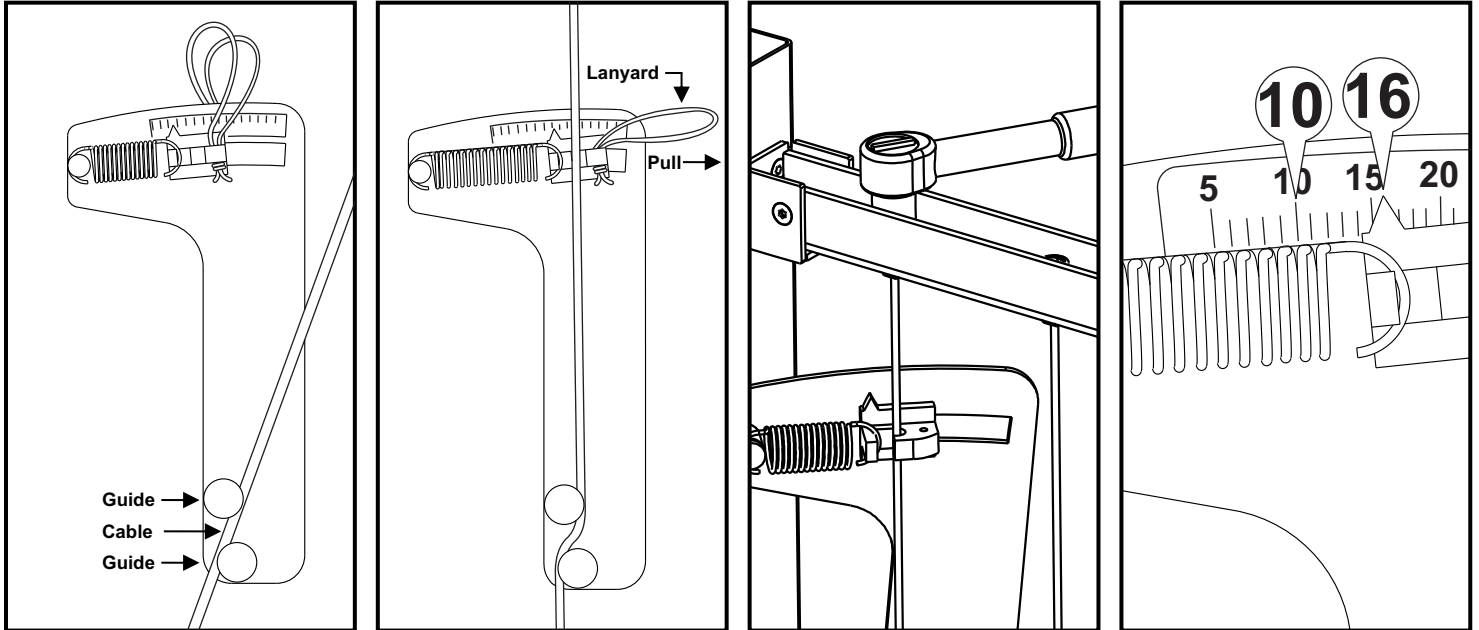

Cable Tensioning Sequence

Remove the slack from the cables using the socket wrench, once the slack is removed, only tension the cables one turn at a time in the sequence shown to maintain even tensioning across the panel.

Use a 13mm Socket Wrench to tighten the cables in the sequence to the right.

Tighten cable until the indicator arrow is between **10** and **16** on the tension gauge.

Once cables are tensioned to the proper range on the tension gauge you may move onto the next steps.

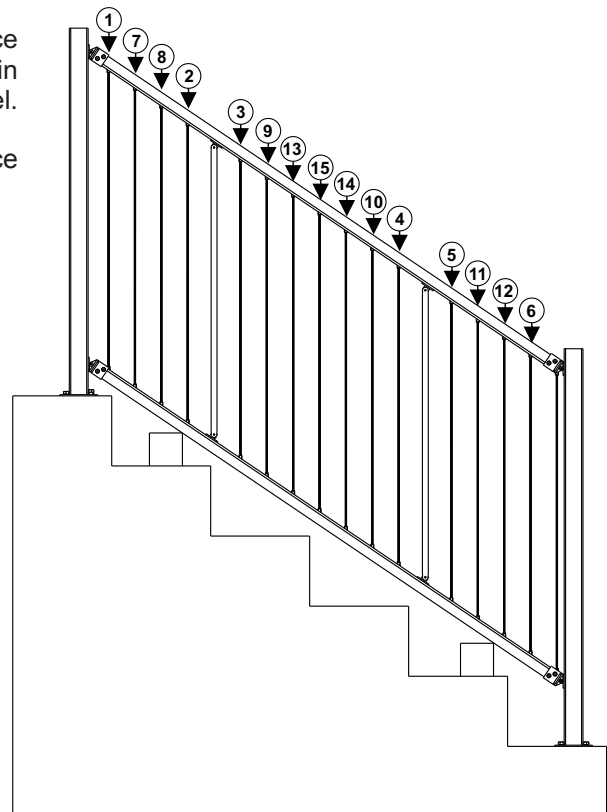

Install Flat Accent Top Rail (ATR) - Option 1

- Measure the distance between posts.
- A minimum of two ATR Spacers are required in order to ensure proper fit of ATR.
- Transfer that measurement to the ATR and cut a equal distance from each end of ATR. Check the fit of ATR.
- File any rough edges from cuts and apply zinc based touch up paint.
- Apply a quarter sized drop of epoxy to the side walls of each ATR Spacer. Follow cure times specified on epoxy packaging.
- Install ATR onto rail and wipe away any excess epoxy with a clean cloth.
- Let epoxy cure. Do not apply any force to installed ATR for 2 hours.

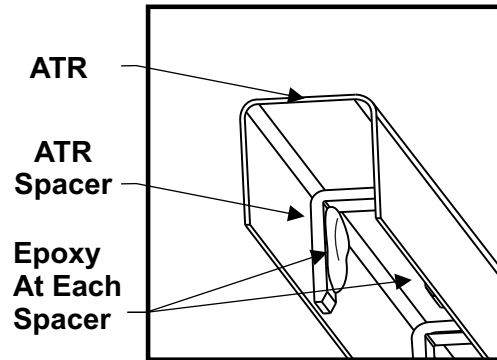
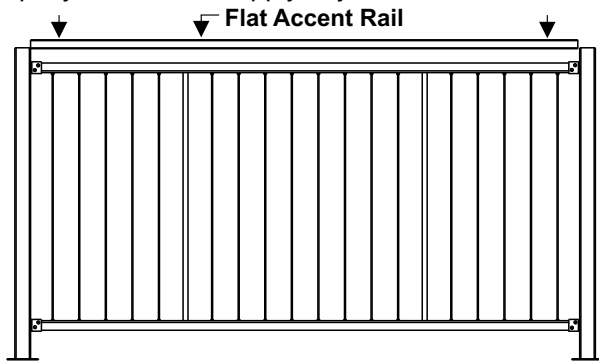

Install Wood or Composite Top Cap - Option 2

- Use a Wood or Composite Top Cap to finish the Top Rail.
- Cut Top Cap to length and secure to Top Rail with Fortress Cap Rail Clips.
- Cap Rail Clips should be equally spaced along the length of Top Cap (**Max Spacing is 28"**).

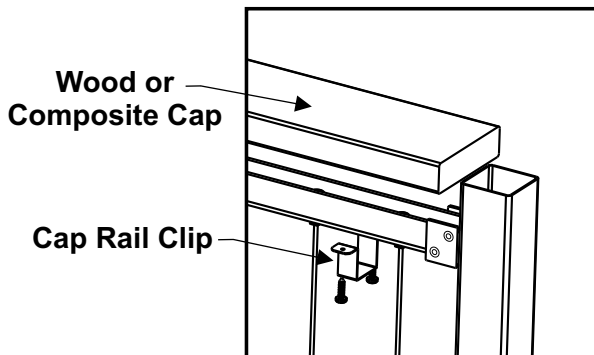
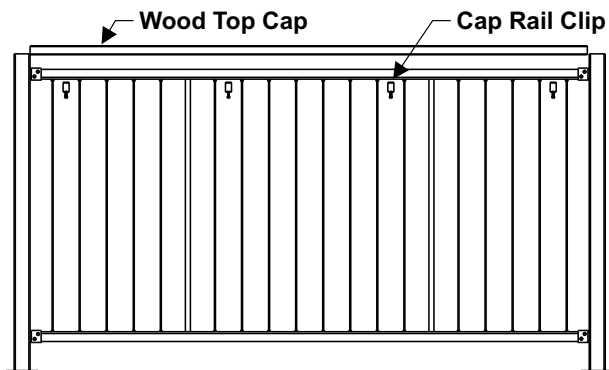

Install UB-05 Caps

- When using a Wood or Composite Top Cap and installing the UB-05 Caps on the Top Rail, the Caps should be installed upside down as shown.
- If using a Fortress Flat Accent Rail, UB-05 Caps will not be used on the Top Rail.

