

Veranda

(Style C70)

Installation Instructions



- These instructions must be followed exactly as written and the materials used must be exactly as shown in the instructions. Any deviation from the instructions or variation in the materials used/installed may result in an unsuccessful installation.
- When core drilling any post product where water can build up, the installer is responsible to drill a 1/4" hole as close to the bottom of the post by concrete as possible. If there is no weep hole, you may have damage from moisture build up and freezing thus potentially voiding the powder coating warranty.

Installing Aluminum Post w/Adjustable Plate

1. Place the (2) stainless steel strips below the plate under the leveling bolts.
2. **a. For general installation:** fasten aluminum post to wood surface using (4) 3/8" x 5" or longer stainless steel lags (lags not included). **WARNING: When installing the Aluminum Post on top of a wood structure, the 5" lags MUST be lagged into at least 4" of solid wood! It will not be strong enough if it is fastened into a 5/4" or a 1 1/2" thick deck board!** Below is an example of how to design the wood structure to accept the Aluminum Post. Any other way must meet or exceed these qualifications.

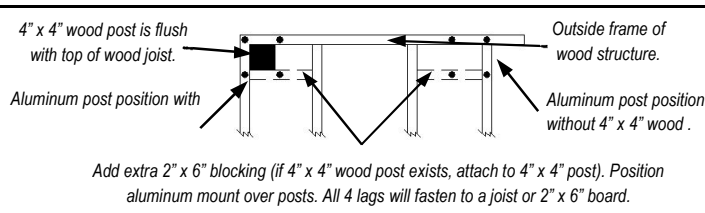

b. For IRC wood surface installation: attach wood blocking to substructure with #10 x 3" wood screws. Fasten aluminum post using (4) 3/8" x 5-1/2" bolts (anchors not included) thru aluminum backer plate (sold separately) as shown below.

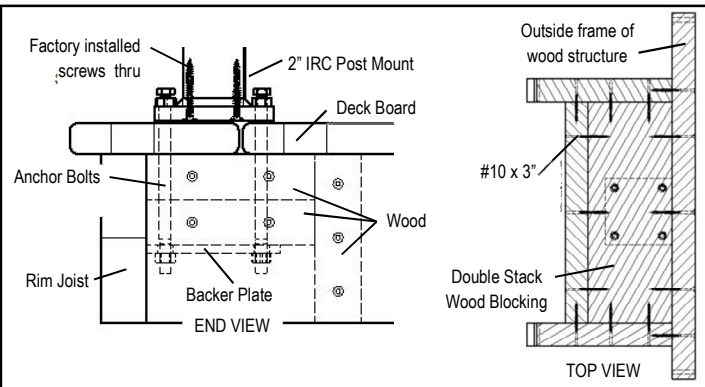

c. For concrete installation, fasten aluminum post to concrete using (4) 3/8" x 3" or longer concrete anchors (anchors not included.)

3. Use a 1/2" open end wrench to level aluminum post with the leveling bolts on the welded plate.
4. Attach caps. Lightly tap with rubber mallet if needed.

Angle (Swivel) Mount

1. **a.** Position bottom mount base so the bottom of the rail has no more than a 2" clearance. **NOTE: A 1 1/2" spacer may be placed on the welded 3/8" plate of the post to reach the 2" clearance. Use 1 1/4" spacer for 1/2" plates.**
b. Measure up 32 3/8" (for 36" tall railing) or 38 3/8" (for 42" tall railing) from top of bottom mount to top of top mount.
2. Keeping base of mount centered and pin hole turned down, fasten base to post with pan head self-tapping screws (provided).

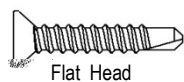

Angle (Swivel) Mount Cont'd

3. Angle swivel mount after mount is installed on post. Measure from back of cup to back of cup to determine rail length. Cut rails.
4. Assemble sections as specified in Standard (Level) Railing, steps 4-7.

Standard (Level) Railing

CAUTION: Glass cannot be cut down or altered.

1. Cut the rails to length by holding rails against posts. Rails are to be cut 1/2" shorter than the distance between the posts. **NOTE: Distance from the post to the edge of the glass cannot be less than 1 1/4" or greater than 4". Mark rails where they are to be cut. NOTE: Make sure rail is cut a 1/4" shorter on each end to allow for mounts. Cut rails.**

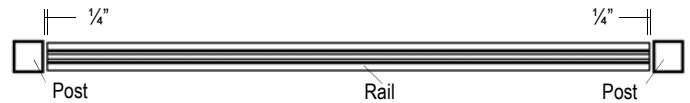

Crossover Railing - Cut bottom rail same as above. For top rail, make end spacing exactly 1" longer on all ends connecting to the crossover post.

2. Attach bottom wall mount to post by positioning the bottom rail so there is no more than a 2" clearance. Keeping mount centered on post, fasten mount to post with pan-head self-tapping screws (provided). **NOTE: A 1 1/2" spacer may be placed on the welded 3/8" plate of the post to reach the 2" clearance. Use 1 1/4" spacer for 1/2" plates.**
3. Attach top wall mount to post by measuring up 32 3/8" (for 36" tall railing) or 38 3/8" (for 42" tall railing) from top of bottom mount to top of top mount. Keeping mount centered on post, fasten mount to post with pan-head self-tapping screws (provided).
4. Place bottom rail into mounts and fasten with flat head self-tapping screws provided.
5. Place top rail into mounts. Secure top rail with flat head self-tapping screws through side of mounts into rail.
6. **NOTE: For glass panels less than 30" wide or heights less than 32", insert glass into bottom rail, then fit top rail down over glass. Attach top rail to mounts.**
7. Before inserting glass panel in top rail, run a wet rag along opening of top rubber insert. (Making end spaces equal) slide glass up far enough to clear bottom rail and align glass with bottom rubber insert. Push glass fully down into bottom rail.

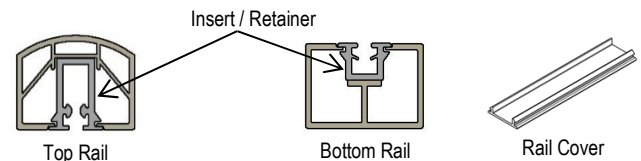
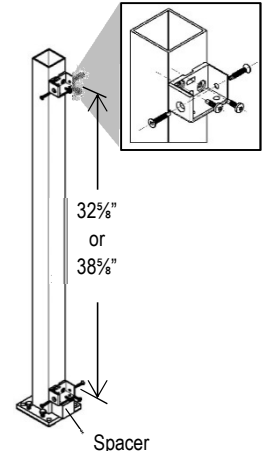

8. Snap rail cover into bottom rail. Rail cover may need to be cut to fit.
9. Place covers on mounts.
10. Attach 2-piece flairs to all posts.

